

EP301R

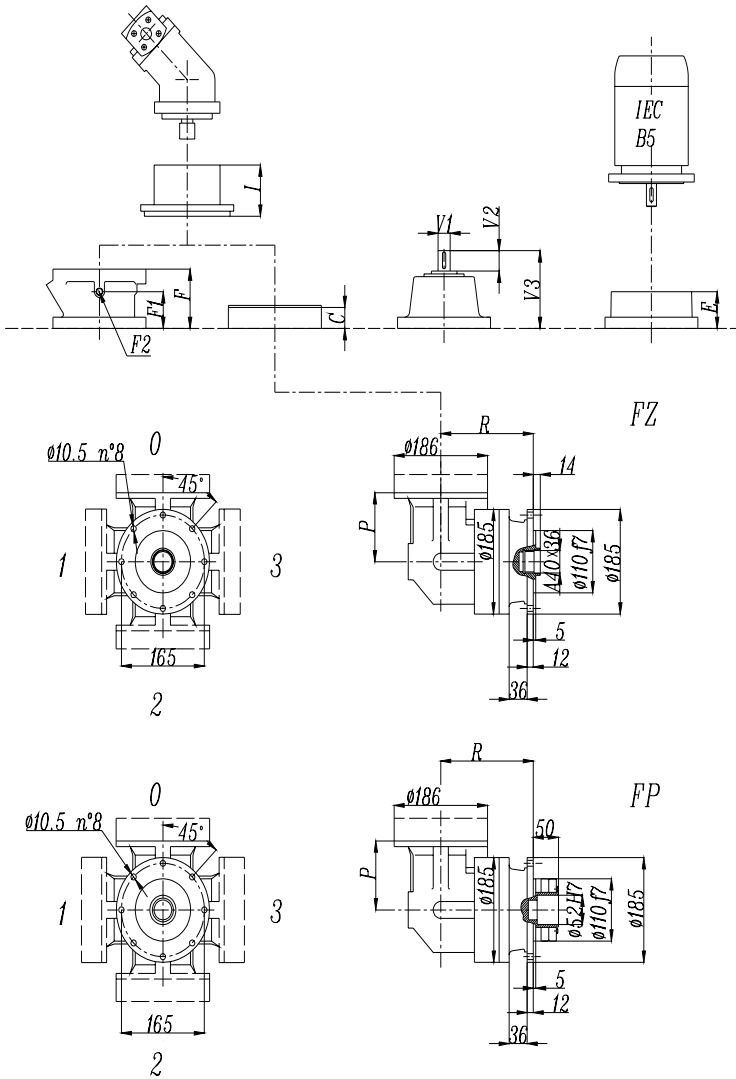

FP version
Max. transmissible
2400 N.m

	R				Ref. weight (without input) (Kg)				C	P	I	Brake				Ref. Weight
	MZ MC	FZ FP	HZ HC	PC PZ	MZ MC	FZ FP	HZ HC	PC PZ				F	F1	F2	Type	
301R2	184	184	219	225	35	33	37	40	37	122	According to hydraulic motor	105	65	1/4 G	4	15 Kg
301R3	237	237	272	278	39	37	41	44	37			105	65	1/4 G	4	
301R4	290	290	325	331	43	41	45	48	37			105	65	1/4 G	4	

E (IEC motor input)							
	IEC71	IEC80	IEC90	IEC100	IEC112	IEC132	
301R2	65	84	84	94	94	114	
301R3	65	84	84	94	94	114	
301R4	65	84	84	94	94	114	

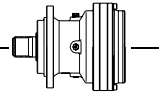

EP301L - EP301R

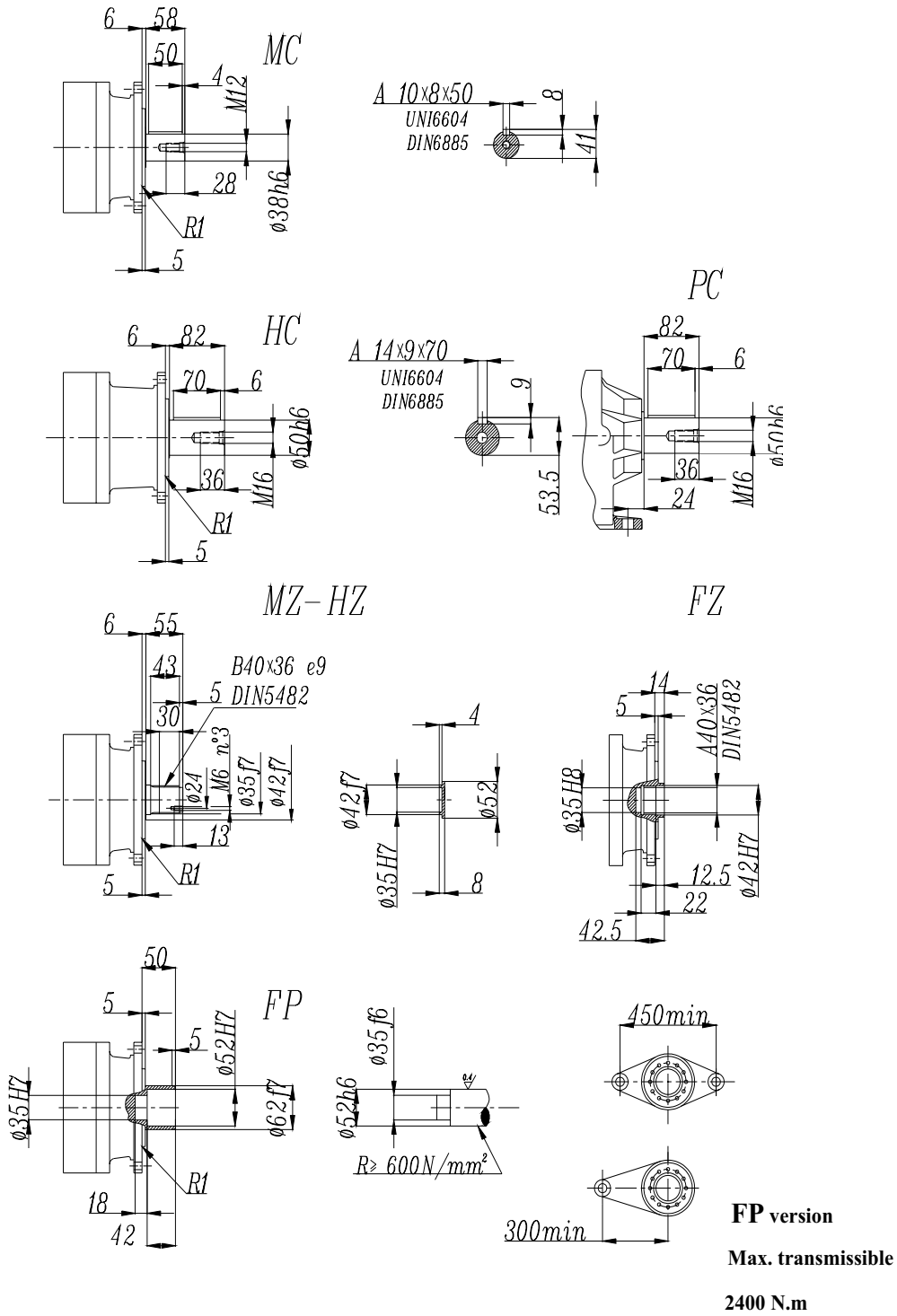

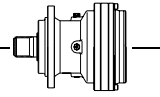

EP301L - EP301R

Drive intake flange

DIF

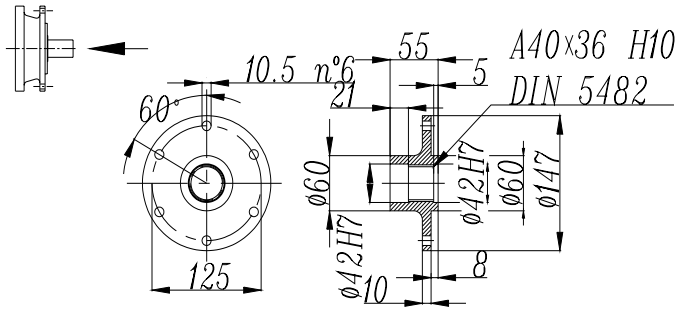

Sleeve couplings

SC

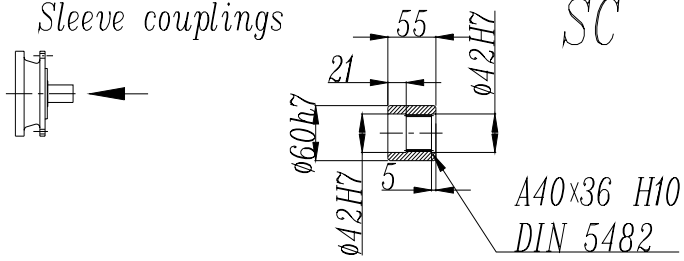

Splined bars

SB

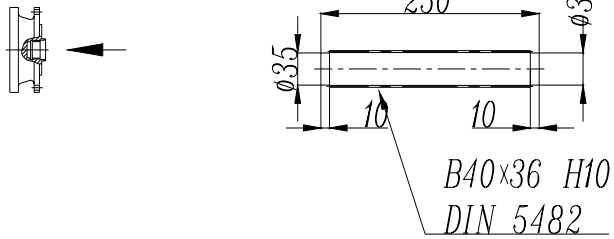

Shrink disc

SD

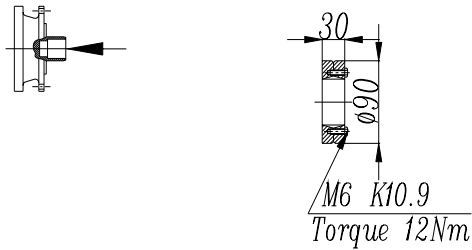

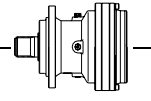

EP301L - EP301R

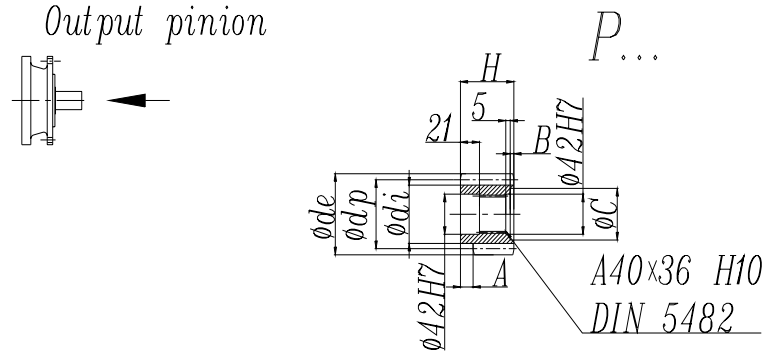

	m	z	x	dp	di	de	H	A	B	C
PBE	4.5	14	0.507	63	56	75.5	55	0	0	0
PCE	5	14	0.500	70	62.5	84.8	65	0	10	53
PDC	6	12	0.250	72	61	84.8	59	14	4	54
PDE	6	14	0.500	84	73	99.6	65	0	10	54

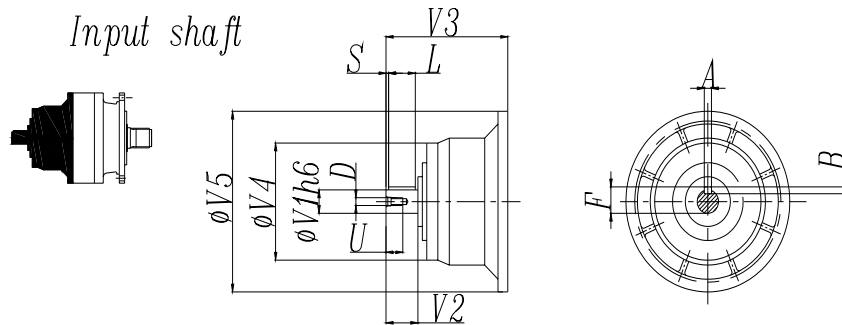

	CODE	V1	V2	V3	V4	V5	A	B	F	L	S	D	U
301L1	V01A	24	36	137.5	120	186	8	7	27	30	3	M8	19
	V01B	38	58	158	120	186	10	8	41	50	4	M12	28
301L2	V01A	24	36	137.5	120	186	8	7	27	30	3	M8	19
	V01B	38	58	158	120	186	10	8	41	50	4	M12	28
301L3	V01A	24	36	137.5	120	186	8	7	27	30	3	M8	19
	V01B	38	58	158	120	186	10	8	41	50	4	M12	28
301L4	V01A	24	36	137.5	120	186	8	7	27	30	3	M8	19
	V01B	38	58	158	120	186	10	8	41	50	4	M12	28
301R2-R3-R4	V01A	24	36	137.5	120	186	8	7	27	30	3	M8	19
	V01B	38	58	158	120	186	10	8	41	50	4	M12	28

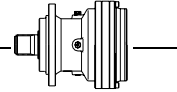

EP301L - EP301R

Permissible radial and axial loads on output shaft with Fh2 ($n_2 \cdot h=10\ 000$)

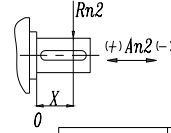
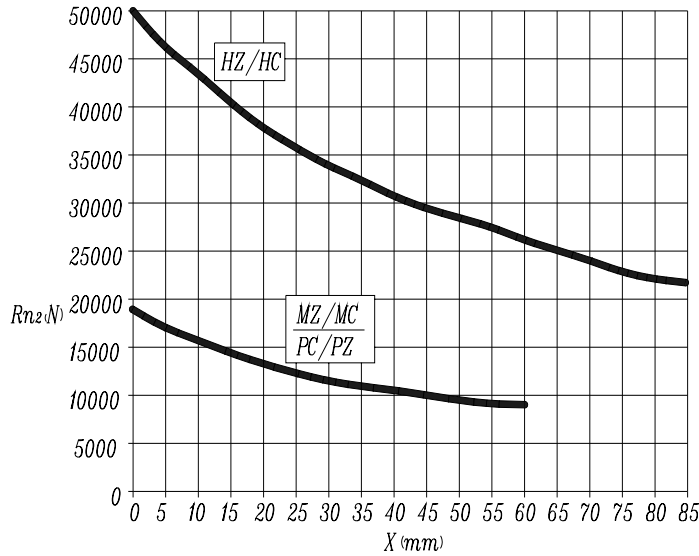

	$An_2(+)$	$An_2(-)$
MZ-MC-PC-PZ	20 000	15 000
HZ-HC	40 000	40 000

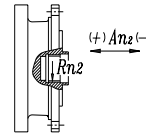

	R_{n2}	$An_2(+/-)$
FZ	8 000	8 000

Load corrective factor fh2 on shafts	fh2= $n_2 \cdot h$		10 000	25 000	50 000	100 000	500 000	1 000 000
	fh2	MZ-MC-PC-PZ-FZ	1	0.74	0.58	0.46	0.27	0.21
		HZ-HC	1	0.76	0.61	0.50	0.31	0.25

Permissible radial loads on input shaft with Fh1 ($n_1 \cdot h=250\ 000$)

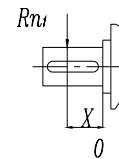
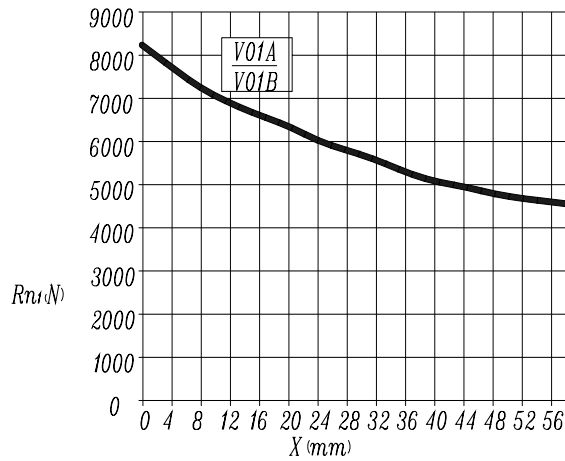

Load corrective factor fh1 on shafts	Fh1= $n_1 \cdot h$		250 000	500 000	1 000 000	2 00 000	5 000 000	10 000 000
	fh1		1	0.79	0.63	0.50	0.37	0.29

Planetary Gearbox

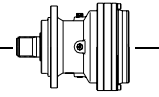

EP303L

M2'=3000N.m

	I 1:	Mn ₂ (N.m)						P ₁ (KW)	P _t (KW) (t _a =20°C) (n ₁ =1500)	n ₁ (min ⁻¹)	n _{1max} (min ⁻¹)	M _b (N.m)	Brake type
		n ₂ .h 10000	n ₂ .h 25000	n ₂ .h 50000	n ₂ .h 100000	n ₂ .h 500000	n ₂ .h 1000000						
L1	3.7	2 900	2 750	2 650	2 600	2 150	1 750	40	11	1 750	3 500	1 000	5K
	4.2	2 900	2 750	2 650	2 600	2 150	1 750	40	11	1 750	3 500	1 000	5K
	5	2 800	2 450	2 200	2 200	2 100	1 700	40	11	1 750	3 500	800	5G
	5.6	2 300	2 000	1 800	1 800	1 750	1 400	40	11	1 750	3 500	630	5E
	6.8	2 000	1 750	1 650	1 650	1 650	1 500	36	11	1 750	3 500	500	5C
L2	12.4	2 900	2 750	2 650	2 600	2 150	1 750	25	9	1 750	3 500	330	4H
	14.2	2 900	2 750	2 650	2 600	2 150	1 750	22	9	1 750	3 500	330	4H
	18.7	2 900	2 750	2 650	2 600	2 150	1 750	17	9	1 750	3 500	260	4F
	24.2	2 900	2 750	2 650	2 600	2 150	1 750	13	9	1 750	3 500	260	4F
	25.2	2 900	2 750	2 650	2 600	2 150	1 750	13	9	1 750	3 500	260	4F
	28.9	2 800	2 450	2 200	2 200	2 100	1 700	12	9	1 750	3 500	160	4D
	30	2 800	2 450	2 200	2 200	2 100	1 700	11.5	9	1 750	3 500	160	4D
	32.1	2 300	2 000	1 800	1 800	1 750	1 400	10	9	1 750	3 500	100	4B
	40.1	2 300	2 000	1 800	1 800	1 750	1 400	8	9	1 750	3 500	100	4B
	49.1	2 000	1 750	1 650	1 650	1 650	1 500	6	9	1 750	3 500	100	4B
L3	48.1	2 900	2 750	2 650	2 600	2 150	1 750	8	7.5	1 750	3 500	100	4B
	55.2	2 900	2 750	2 650	2 600	2 150	1 750	7	7.5	1 750	3 500	100	4B
	63.2	2 900	2 750	2 650	2 600	2 150	1 750	6.2	7.5	1 750	3 500	100	4B
	71.6	2 900	2 750	2 650	2 600	2 150	1 750	5.5	7.5	1 750	3 500	50	4A
	82	2 900	2 750	2 650	2 600	2 150	1 750	5	7.5	1 750	3 500	50	4A
	108	2 900	2 750	2 650	2 600	2 150	1 750	4	7.5	1 750	3 500	50	4A
	140	2 900	2 750	2 650	2 600	2 150	1 750	3.2	7.5	1 750	3 500	50	4A
	174	2 900	2 750	2 650	2 600	2 150	1 750	2.6	7.5	1 750	3 500	50	4A
	208	2 800	2 450	2 200	2 200	2 100	1 700	1.8	7.5	1 750	3 500	50	4A
	259	2 300	2 000	1 800	1 800	1 750	1 400	1.2	7.5	1 750	3 500	50	4A
354	2 000	1 750	1 650	1 650	1 650	1 500	0.8	7.5	1 750	3 500	50	4A	
L4	278	2 900	2 750	2 650	2 600	2 150	1 750	1.5	6	1 750	3 500	50	4A
	318	2 900	2 750	2 650	2 600	2 150	1 750	1.3	6	1 750	3 500	50	4A
	365	2 900	2 750	2 650	2 600	2 150	1 750	1.2	6	1 750	3 500	50	4A
	413	2 900	2 750	2 650	2 600	2 150	1 750	1	6	1 750	3 500	50	4A
	473	2 900	2 750	2 650	2 600	2 150	1 750	0.9	6	1 750	3 500	50	4A
	621	2 900	2 750	2 650	2 600	2 150	1 750	0.7	6	1 750	3 500	50	4A
	745	2 900	2 750	2 650	2 600	2 150	1 750	0.65	6	1 750	3 500	50	4A
	806	2 900	2 750	2 650	2 600	2 150	1 750	0.6	6	1 750	3 500	50	4A
	1007	2 900	2 750	2 650	2 600	2 150	1 750	0.5	6	1 750	3 500	50	4A
	1256	2 900	2 750	2 650	2 600	2 150	1 750	0.4	6	1 750	3 500	50	4A
1495	2 800	2 450	2 200	2 200	2 100	1 700	0.3	6	1 750	3 500	50	4A	
1866	2 300	2 000	1 800	1 800	1 750	1 400	0.2	6	1 750	3 500	50	4A	
2545	2 000	1 750	1 650	1 650	1 650	1 500	0.14	6	1 750	3 500	50	4A	

$M_{2max}=1.2 \times Mn_2(n_2 \times h=10\ 000)$

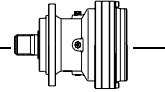

EP303R

M2'=3000N.m

	I 1:	Mn ₂ (N.m)						P ₁ (KW)	P _t (KW) (t _a =20°C) (n ₁ =1500)	n ₁ (min ⁻¹)	n _{1max} (min ⁻¹)	M _b (N.m)	Brake type
		n _{2,h} 10000	n _{2,h} 25000	n _{2,h} 50000	n _{2,h} 100000	n _{2,h} 500000	n _{2,h} 1000000						
R2	9.4	2 900	2 750	2 650	2 600	2 150	1 750	35	18	1 750	3 500	400	4K
	10.8	2 900	2 750	2 650	2 600	2 150	1 750	35	18	1 750	3 500	400	4K
	12.8	2 800	2 450	2 200	2 200	2 100	1 700	27	18	1 750	3 500	330	4H
	14.3	2 300	2 000	1 800	1 800	1 750	1 400	18.9	18	1 750	3 500	260	4F
	17.5	2 000	1 750	1 650	1 650	1 650	1 500	14.3	18	1 750	3 500	160	4D
R3	25.4	2 900	2 750	2 650	2 600	2 150	1 750	14.3	14	1 750	3 500	160	4D
	29.1	2 900	2 750	2 650	2 600	2 150	1 750	15.3	14	1 750	3 500	160	4D
	38.3	2 900	2 750	2 650	2 600	2 150	1 750	12.4	14	1 750	3 500	100	4B
	49.7	2 900	2 750	2 650	2 600	2 150	1 750	8.7	14	1 750	3 500	100	4B
	51.7	2 900	2 750	2 650	2 600	2 150	1 750	9.2	14	1 750	3 500	100	4B
	51.9	2 800	2 450	2 200	2 200	2 100	1 700	6.8	14	1 750	3 500	100	4B
	59.1	2 800	2 450	2 200	2 200	2 100	1 700	4.8	14	1 750	3 500	100	4B
	61.5	2 800	2 450	2 200	2 200	2 100	1 700	5.6	14	1 750	3 500	100	4B
	65.9	2 300	2 000	1 800	1 800	1 750	1 400	4.5	14	1 750	3 500	50	4A
	82.3	2 300	2 000	1 800	1 800	1 750	1 400	3.7	14	1 750	3 500	50	4A
	101	2 000	1 750	1 650	1 650	1 650	1 500	3	14	1 750	3 500	50	4A
R4	98.6	2 900	2 750	2 650	2 600	2 150	1 750	4	12	1 750	3 500	50	4A
	113	2 900	2 750	2 650	2 600	2 000	1 650	3.6	12	1 750	3 500	50	4A
	130	2 900	2 750	2 650	2 600	2 150	1 750	3.2	12	1 750	3 500	50	4A
	147	2 900	2 750	2 650	2 600	2 000	1 650	2.9	12	1 750	3 500	50	4A
	168	2 900	2 750	2 650	2 600	2 150	1 750	2.6	12	1 750	3 500	50	4A
	221	2 900	2 750	2 650	2 600	2 000	1 650	2	12	1 750	3 500	50	4A
	287	2 900	2 750	2 650	2 600	2 150	1 750	1.6	12	1 750	3 500	50	4A
	358	2 900	2 750	2 650	2 600	2 000	1 650	1.3	12	1 750	3 500	50	4A
	426	2 800	2 450	2 200	2 200	2 100	1 700	0.9	12	1 750	3 500	50	4A
	531	2 300	2 000	1 800	1 800	1 750	1 400	0.6	12	1 750	3 500	50	4A
	725	2 000	1 750	1 650	1 650	1 650	1 500	0.43	12	1 750	3 500	50	4A

$$M_{2max}=1.2 \times Mn_2(n_2 \times h=10\ 000)$$

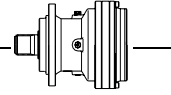

EP303L

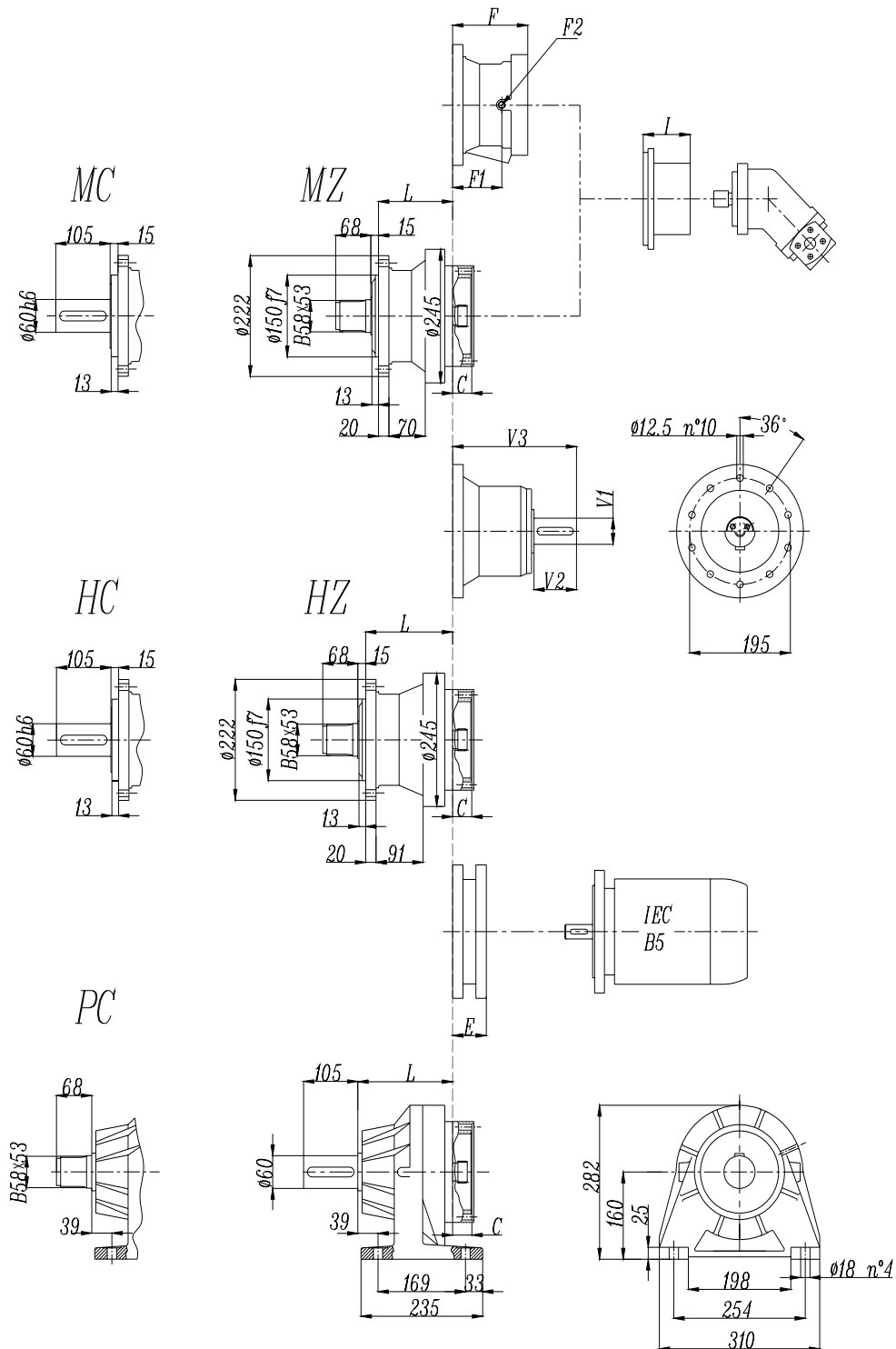

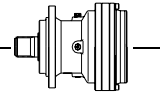

EP303L

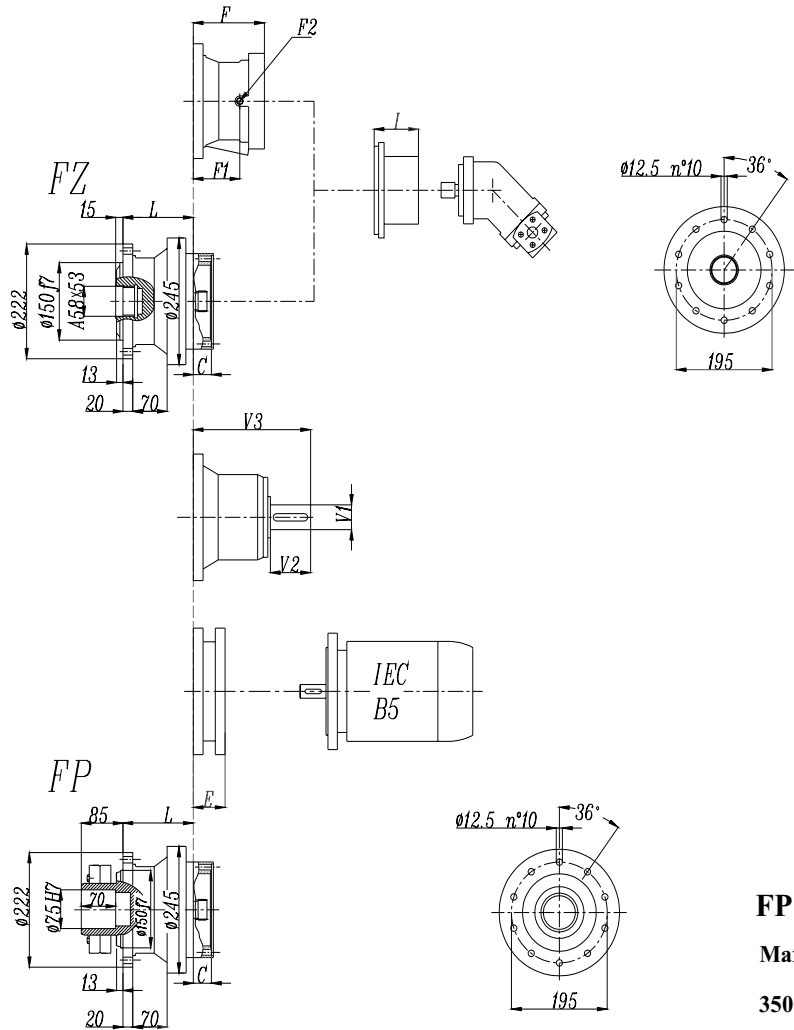

FP version
Max. transmissible
3500 N.m

	L				Ref. weight (without input) (Kg)				C	I	Brake				
	MZ MC	FZ FP	HZ HC	PC PZ	MZ MC	FZ FP	HZ HC	PC PZ			F	F1	F2	Type	Ref. Weight
303L1	129	129	154	169	31	31	35	40	37	According to hydraulic motor	145	95	1/4 G	5	15 Kg
303L2	182	182	207	222	35	35	39	44	37		105	65	1/4 G	4	
303L3	234	234	260	275	39	39	43	48	37		105	65	1/4 G	4	
303L4	288	288	313	328	43	43	47	52	37		105	65	1/4 G	4	

	E (IEC motor input)										
			IEC71	IEC80	IEC90	IEC100	IEC112	IEC132	IEC160	IEC180	IEC200
303L1								114	144	144	174
303L2			65	84	84	94	94	114	144		
303L3			65	84	84	94	94	114	144		
303L4			65	84	84	94	94	114	144		

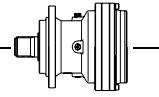

EP303R

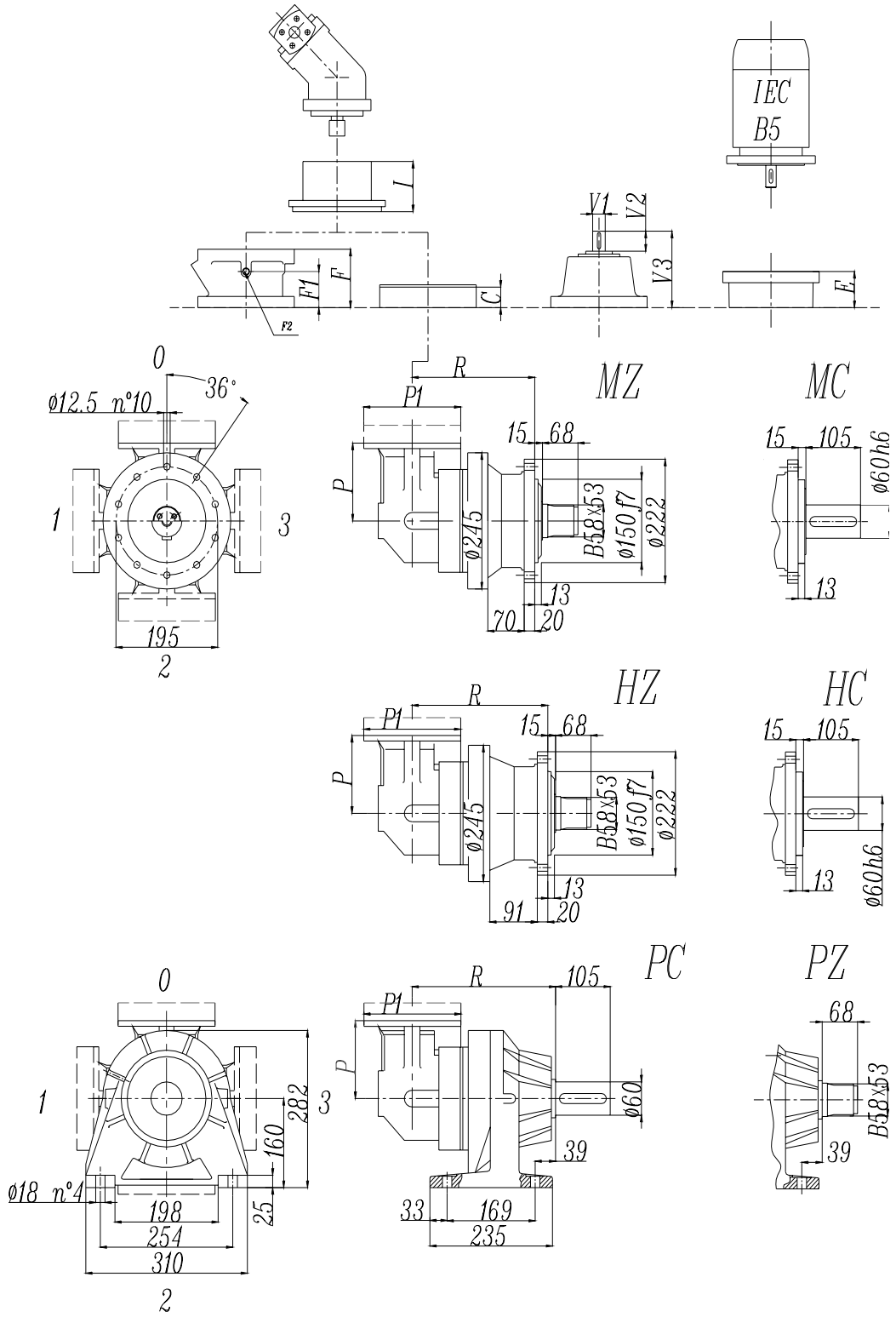

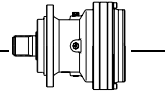

EP303R

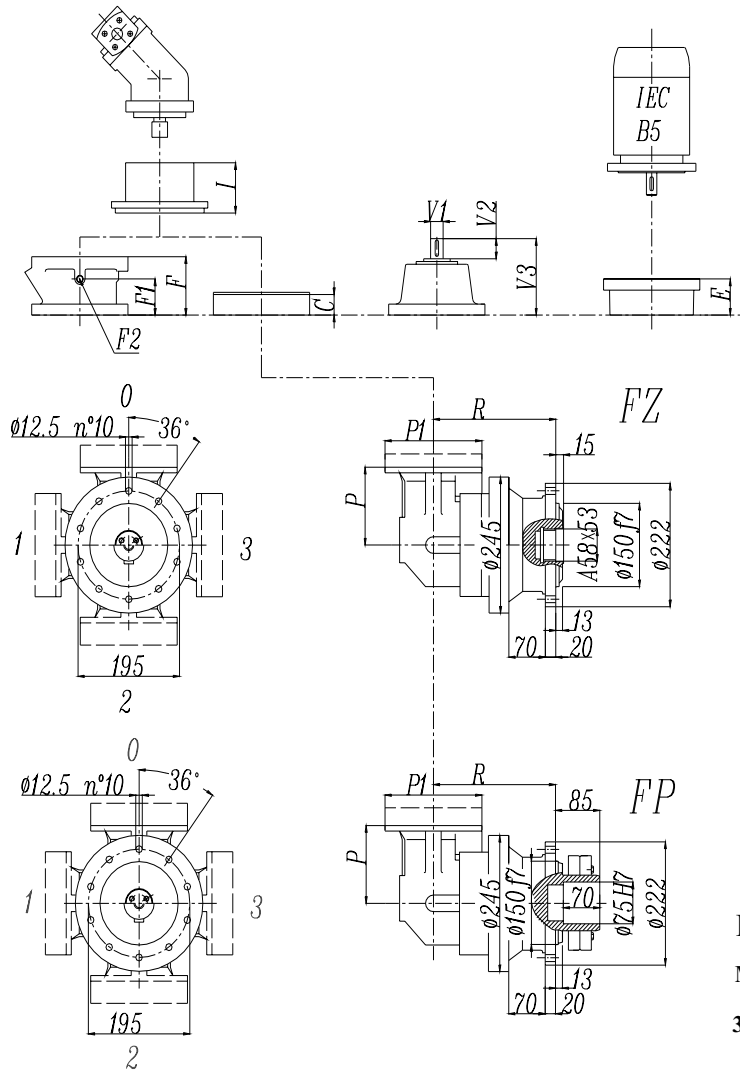

FP version
Max. transmissible
3500 N.m

	R				Ref. weight (without input) (Kg)				C	P	I	Brake				Ref. Weight
	MZ MC	FZ FP	HZ HC	PC PZ	MZ MC	FZ FP	HZ HC	PC PZ				F	F1	F2	Type	
303R2	221	221	246	261	51	51	55	60	37	140	According to hydraulic motor	105	65	1/4 G	4	15 Kg
303R3	274	274	299	314	49	49	53	58	37	122		105	65	1/4 G	4	
303R4	327	327	352	367	53	53	57	62	37	122		105	65	1/4 G	4	

	P1	E (IEC motor input)					
		IEC71	IEC80	IEC90	IEC100	IEC112	IEC132
303R2	186	65	84	84	94	94	114
303R3	186	65	84	84	94	94	114
303R4	186	65	84	84	94	94	114

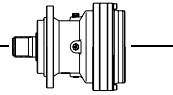

EP303L - EP303R

MC-HC

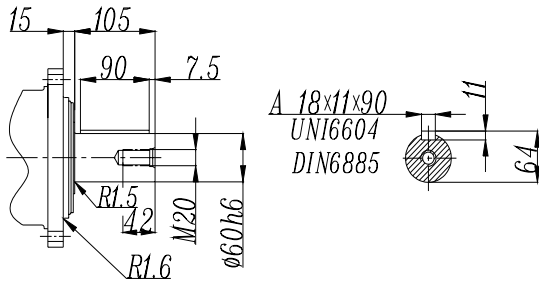

PC

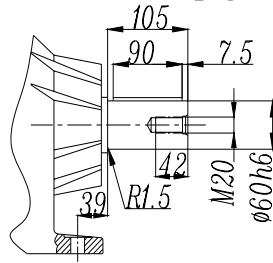

MZ-HZ

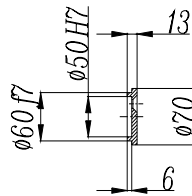
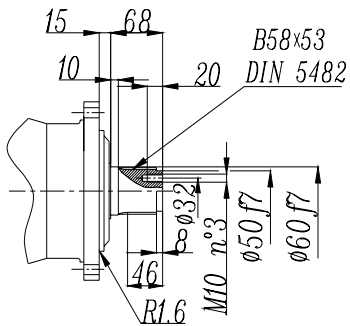

FZ

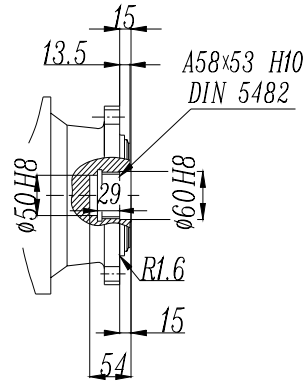

FP

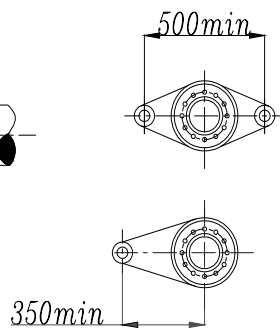
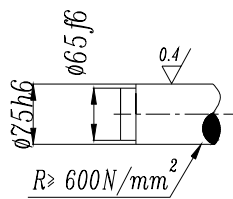
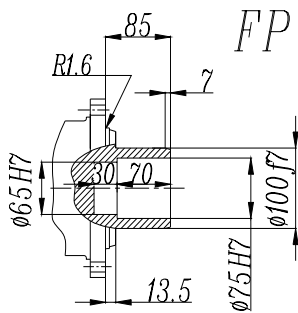

FP version

Max. transmissible

3500 N.m

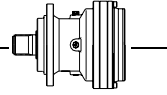

EP303L - EP303R

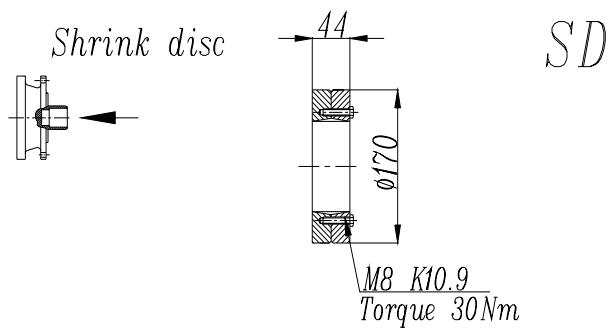
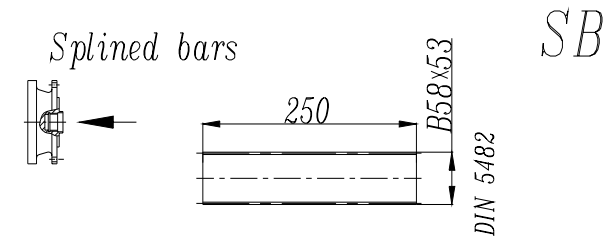
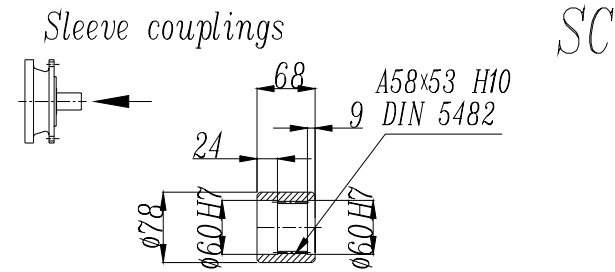
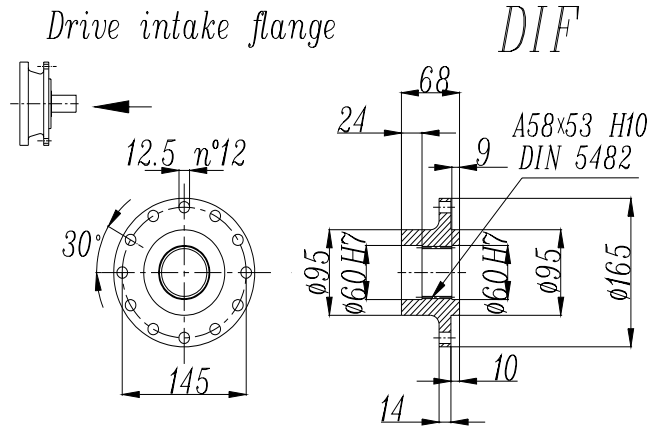

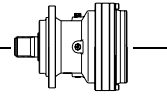

EP303L - EP303R

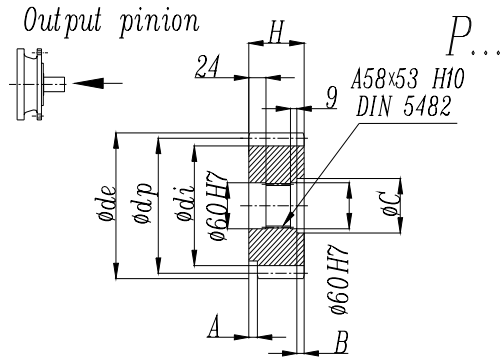

	m	z	x	dp	di	de	H	A	B	C
PCL1	5	19	0	95	82	104	77	12	9	72
PCL2	5	19	0	95	82	104	68	0	0	0
PCM	5	20	0	100	87.5	110	68	18	0	0
PCP	5	22	0	110	97.5	120	68	18	0	0
PDE	6	14	0.5000	84	75	99.6	68	0	0	0
PDI	6	18	0.5000	108	99	123.6	68	0	0	0
PDM	6	20	0.833	120	115	140	68	0	0	0
PFD	8	13	0.675	104	95	127.6	68	0	0	0
PFE1	8	14	0	112	92	126	68	0	0	0
PFE2	8	14	0	112	92	126	80	0	12	72
PFE	8	15	0	120	100	136	68	0	0	0
PFP	8	22	0	176	156	190	77	12	10	71
PHG	10	16	0.5000	160	145	188	75	0	7	72

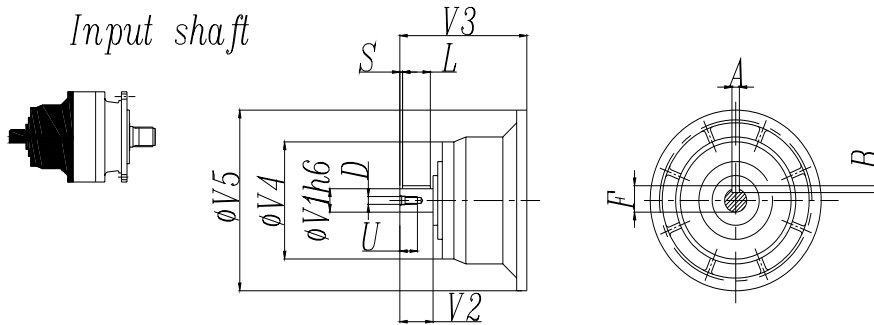

	CODE	V1	V2	V3	V4	V5	A	B	F	L	S	D	U
303L1	V05B	48	82	239	155	245	14	9	51.5	70	6	M16	36
303L2	V01A	24	36	137.5	120	186	8	7	27	30	3	M8	19
	V01B	38	58	158	120	186	10	8	41	50	4	M12	28
303L3	V01A	24	36	137.5	120	186	8	7	27	30	3	M8	19
	V01B	38	58	158	120	186	10	8	41	50	4	M12	28
303L4	V01A	24	36	137.5	120	186	8	7	27	30	3	M8	19
	V01B	38	58	158	120	186	10	8	41	50	4	M12	28
303R2-R3-R4	V01A	24	36	137.5	120	186	8	7	27	30	3	M8	19
	V01B	38	58	158	120	186	10	8	41	50	4	M12	28

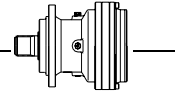

EP303L - EP303R

Permissible radial and axial loads on output shaft with Fh2 ($n_2 \cdot h=10\ 000$)

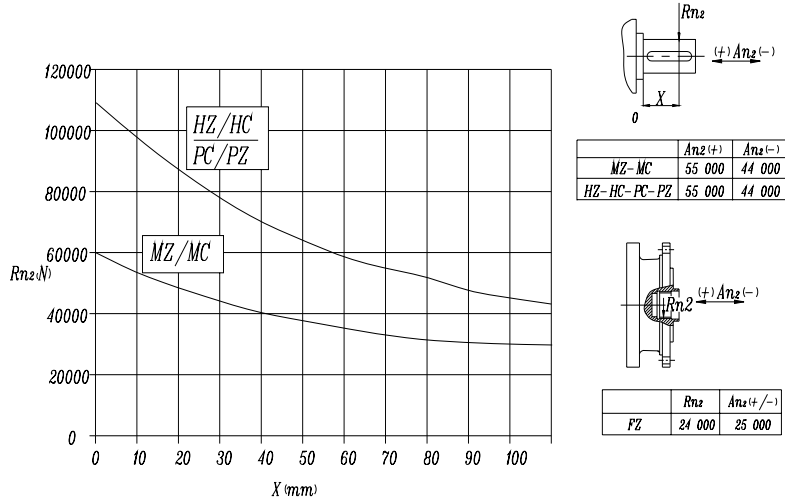

Load corrective factor fh2 on shafts	fh2= $n_2 \cdot h$		10 000	25 000	50 000	100 000	500 000	1 000 000
	fh2	MZ-MC-PC-PZ-FZ	1	0.74	0.58	0.46	0.27	0.21
		HZ-HC	1	0.76	0.61	0.50	0.31	0.25

Permissible radial loads on input shaft with Fh1 ($n_1 \cdot h=250\ 000$)

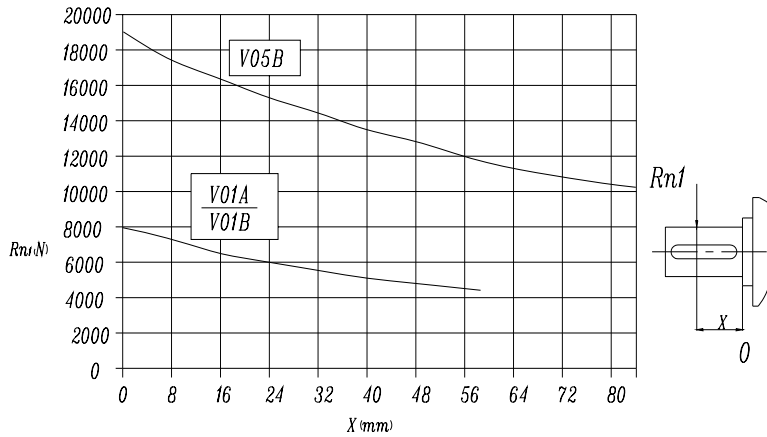

Load corrective factor fh1 on shafts	Fh1= $n_1 \cdot h$	250 000	500 000	1 000 000	2 00 000	5 000 000	10 000 000
	fh1	1	0.79	0.63	0.50	0.37	0.29

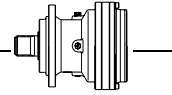

EP305L

M2'=5000N.m

	I 1:	Mn ₂ (N.m)						P ₁ (KW)	P _t (KW) (t _a =20°C) (n ₁ =1500)	n ₁ (min ⁻¹)	n _{1max} (min ⁻¹)	M _b (N.m)	Brake type
		n ₂ .h 10000	n ₂ .h 25000	n ₂ .h 50000	n ₂ .h 100000	n ₂ .h 500000	n ₂ .h 1000000						
L1	3.7	5 800	5 500	5 300	5 200	3 700	3 000	60	13	1 750	3 500	1 000	5K
	4.2	5 800	5 500	5 300	5 200	3 700	3 000	60	13	1 750	3 500	1 000	5K
	5	5 600	5 100	4 400	4 400	3 600	2 950	60	13	1 750	3 500	1 000	5K
	5.6	4 600	3 950	3 600	3 600	3 500	2 900	60	13	1 750	3 500	1 000	5K
	6.8	3 800	3 300	3 100	3 100	3 000	2 400	50	13	1 750	3 500	800	5G
L2	12.4	5 800	5 500	5 300	5 200	3 700	3 000	30	9	1 750	3 500	440	4L
	14.2	5 800	5 500	5 300	5 200	3 700	3 000	30	9	1 750	3 500	440	4L
	18.7	5 800	5 500	5 300	5 200	3 700	3 000	25	9	1 750	3 500	400	4K
	24.2	5 800	5 500	5 300	5 200	3 700	3 000	22	9	1 750	3 500	260	4F
	25.2	5 800	5 500	5 300	5 200	3 700	3 000	22	9	1 750	3 500	260	4F
	28.9	5 600	5 100	4 400	4 400	3 600	2 950	20	9	1 750	3 500	260	4F
	30	5 600	5 100	4 400	4 400	3 600	2 950	19.5	9	1 750	3 500	260	4F
	32.1	4 600	3 950	3 600	3 600	3 500	2 900	18	9	1 750	3 500	260	4F
	40.1	4 600	3 950	3 600	3 600	3 500	2 900	15	9	1 750	3 500	160	4D
	49.1	3 800	3 300	3 100	3 100	3 000	2 400	10	9	1 750	3 500	100	4B
L3	48.1	5 800	5 500	5 300	5 200	3 700	3 000	12	7.5	1 750	3 500	160	4D
	55.2	5 800	5 500	5 300	5 200	3 700	3 000	10	7.5	1 750	3 500	100	4B
	63.2	5 800	5 500	5 300	5 200	3 700	3 000	9	7.5	1 750	3 500	100	4B
	71.6	5 800	5 500	5 300	5 200	3 700	3 000	9	7.5	1 750	3 500	100	4B
	82	5 800	5 500	5 300	5 200	3 700	3 000	9	7.5	1 750	3 500	100	4B
	108	5 800	5 500	5 300	5 200	3 700	3 000	7	7.5	1 750	3 500	100	4B
	140	5 800	5 500	5 300	5 200	3 700	3 000	6.2	7.5	1 750	3 500	100	4B
	174	5 800	5 500	5 300	5 200	3 700	3 000	5	7.5	1 750	3 500	50	4A
	208	5 600	5 100	4 400	4 400	3 600	2 950	3.8	7.5	1 750	3 500	50	4A
	259	4 600	3 950	3 600	3 600	3 500	2 900	2.4	7.5	1 750	3 500	50	4A
354	3 800	3 300	3 100	3 100	3 000	2 400	1.5	7.5	1 750	3 500	50	4A	
L4	318	5 800	5 500	5 300	5 200	3 700	3 000	2.9	6	1 750	3 500	50	4A
	365	5 800	5 500	5 300	5 200	3 700	3 000	2.6	6	1 750	3 500	50	4A
	413	5 800	5 500	5 300	5 200	3 700	3 000	2.3	6	1 750	3 500	50	4A
	473	5 800	5 500	5 300	5 200	3 700	3 000	2	6	1 750	3 500	50	4A
	621	5 800	5 500	5 300	5 200	3 700	3 000	1.5	6	1 750	3 500	50	4A
	745	5 800	5 500	5 300	5 200	3 700	3 000	1.3	6	1 750	3 500	50	4A
	806	5 800	5 500	5 300	5 200	3 700	3 000	1.2	6	1 750	3 500	50	4A
	1007	5 800	5 500	5 300	5 200	3 700	3 000	1	6	1 750	3 500	50	4A
	1256	5 800	5 500	5 300	5 200	3 700	3 000	0.7	6	1 750	3 500	50	4A
	1495	5 600	5 100	4 400	4 400	3 600	2 950	0.55	6	1 750	3 500	50	4A
1866	4 600	3 950	3 600	3 600	3 500	2 900	0.37	6	1 750	3 500	50	4A	
2545	3 800	3 300	3 100	3 100	3 000	2 400	0.25	6	1 750	3 500	50	4A	
M_{2max}=1.2×Mn₂(n₂×h=10 000)													

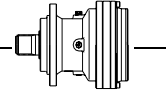

EP305R

M2'=5000N.m

	I 1:	Mn ₂ (N.m)						P ₁ (KW)	P _t (KW) (t _a =20°C) (n ₁ =1500)	n ₁ (min ⁻¹)	n _{1max} (min ⁻¹)	M _b (N.m)	Brake type
		n _{2,h} 10000	n _{2,h} 25000	n _{2,h} 50000	n _{2,h} 100000	n _{2,h} 500000	n _{2,h} 1000000						
R2	9.4	4 600	4 000	3 500	3 200	2 000	1 600	35	18	1 750	3 500	440	4L
	10.8	5 000	4 600	4 100	3 500	2 100	1 700	35	18	1 750	3 500	440	4L
	12.8	5 300	4 900	4 400	4 200	2 600	2 100	27	18	1 750	3 500	440	4L
	14.3	4 600	3 950	3 600	3 600	3 500	2 900	18.9	18	1 750	3 500	330	4H
	17.5	3 800	3 300	3 100	3 100	3 000	2 400	14.3	18	1 750	3 500	260	4F
R3	25.4	5 000	4 600	4 100	3 500	2 100	1 700	13	14	1 750	3 500	260	4F
	29.1	5 300	4 900	4 400	4 200	2 600	2 100	15	14	1 750	3 500	260	4F
	38.3	5 800	5 500	5 300	5 200	3 700	3 000	14	14	1 750	3 500	260	4F
	49.7	5 800	5 500	5 300	5 200	3 700	3 000	12	14	1 750	3 500	160	4D
	51.4	5 800	5 500	5 300	5 200	3 700	3 000	12	14	1 750	3 500	160	4D
	59.1	5 600	5 100	4 400	4 400	3 600	2 950	10	14	1 750	3 500	160	4D
	61.5	5 600	5 100	4 400	4 400	3 600	2 950	10	14	1 750	3 500	100	4B
	65.9	4 600	3 950	3 600	3 600	3 500	2 900	9	14	1 750	3 500	100	4B
	82.2	4 600	3 950	3 600	3 600	3 500	2 900	7	14	1 750	3 500	100	4B
	101	3 800	3 300	3 100	3 100	3 000	2 400	5.3	14	1 750	3 500	50	4A
R4	98.6	5 800	5 500	5 300	5 200	3 700	3 000	7	12	1 750	3 500	100	4B
	113	5 800	5 500	5 300	5 200	3 700	3 000	6.1	12	1 750	3 500	100	4B
	130	5 800	5 500	5 300	5 200	3 700	3 000	5.5	12	1 750	3 500	50	4A
	147	5 800	5 500	5 300	5 200	3 700	3 000	5	12	1 750	3 500	50	4A
	168	5 800	5 500	5 300	5 200	3 700	3 000	4.5	12	1 750	3 500	50	4A
	221	5 800	5 500	5 300	5 200	3 700	3 000	4	12	1 750	3 500	50	4A
	287	5 800	5 500	5 300	5 200	3 700	3 000	3.3	12	1 750	3 500	50	4A
	358	5 800	5 500	5 300	5 200	3 700	3 000	2.6	12	1 750	3 500	50	4A
	426	5 600	5 100	4 400	4 400	3 600	2 950	1.9	12	1 750	3 500	50	4A
	531	4 600	3 950	3 600	3 600	3 500	2 900	1.2	12	1 750	3 500	50	4A
	725	3 800	3 300	3 100	3 100	3 000	2 400	0.75	12	1 750	3 500	50	4A

$$M_{2max}=1.2 \times Mn_2(n_2 \times h=10\ 000)$$

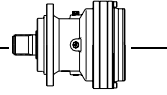

EP305L

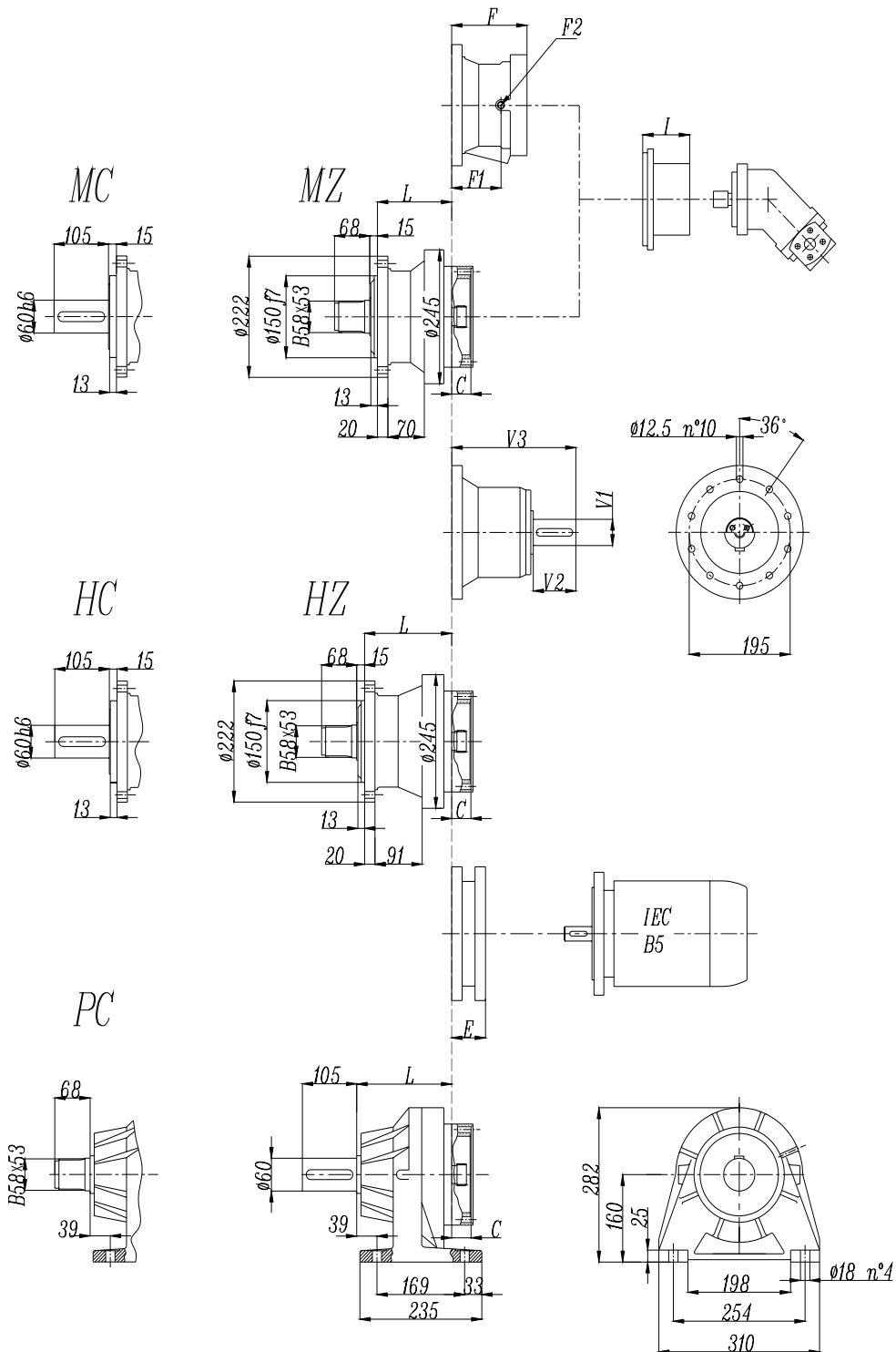

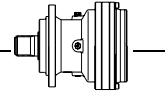

EP305L

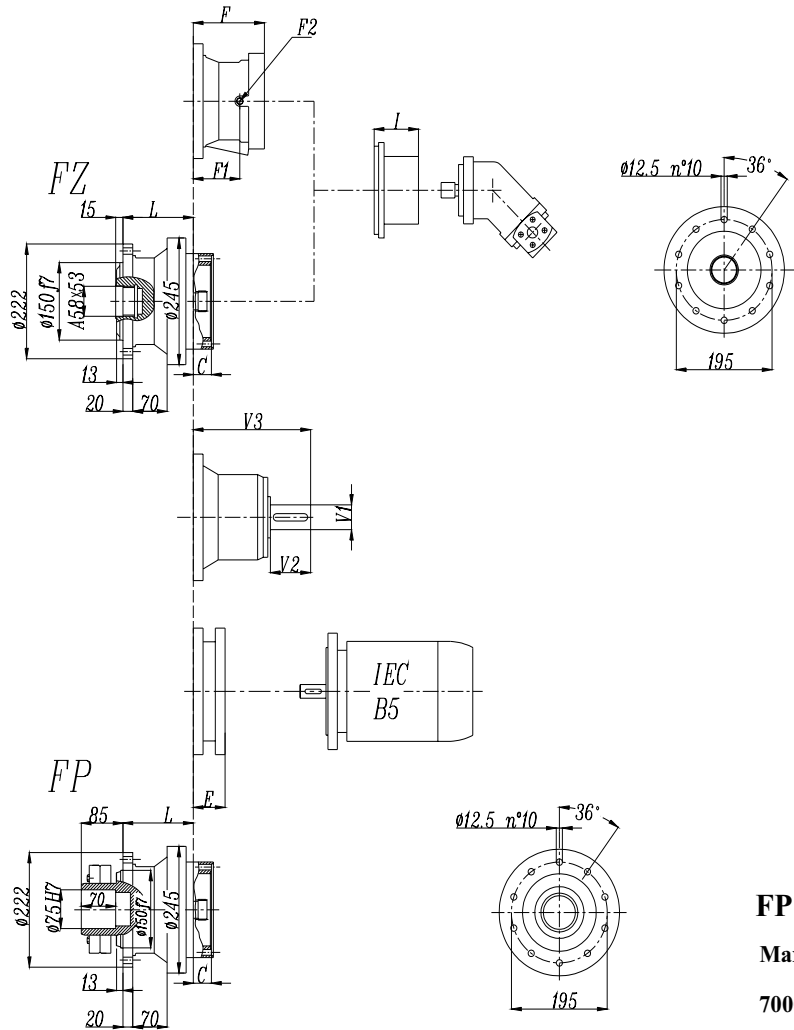

FP version
Max. transmissible
7000 N.m

	L				Ref. weight (without input) (Kg)				C	I	Brake				
	MZ MC	FZ FP	HZ HC	PC PZ	MZ MC	FZ FP	HZ HC	PC PZ			F	F1	F2	Type	Ref. Weight
305L1	147	147	172	187	36	36	40	45	37	According to hydraulic motor	145	95	1/4 G	5	22 Kg
305L2	212	212	237	252	43	43	47	52	37		105	65	1/4 G	4	
305L3	265	265	292	305	47	47	51	56	37		105	65	1/4 G	4	
305L4	318	318	343	358	51	51	55	60	37		105	65	1/4 G	4	

	E (IEC motor input)										
			IEC71	IEC80	IEC90	IEC100	IEC112	IEC132	IEC160	IEC180	IEC200
305L1								114	144	144	174
305L2			65	84	84	94	94	114	144		
305L3			65	84	84	94	94	114	144		
305L4			65	84	84	94	94	114	144		

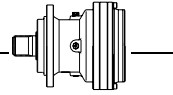

EP305R

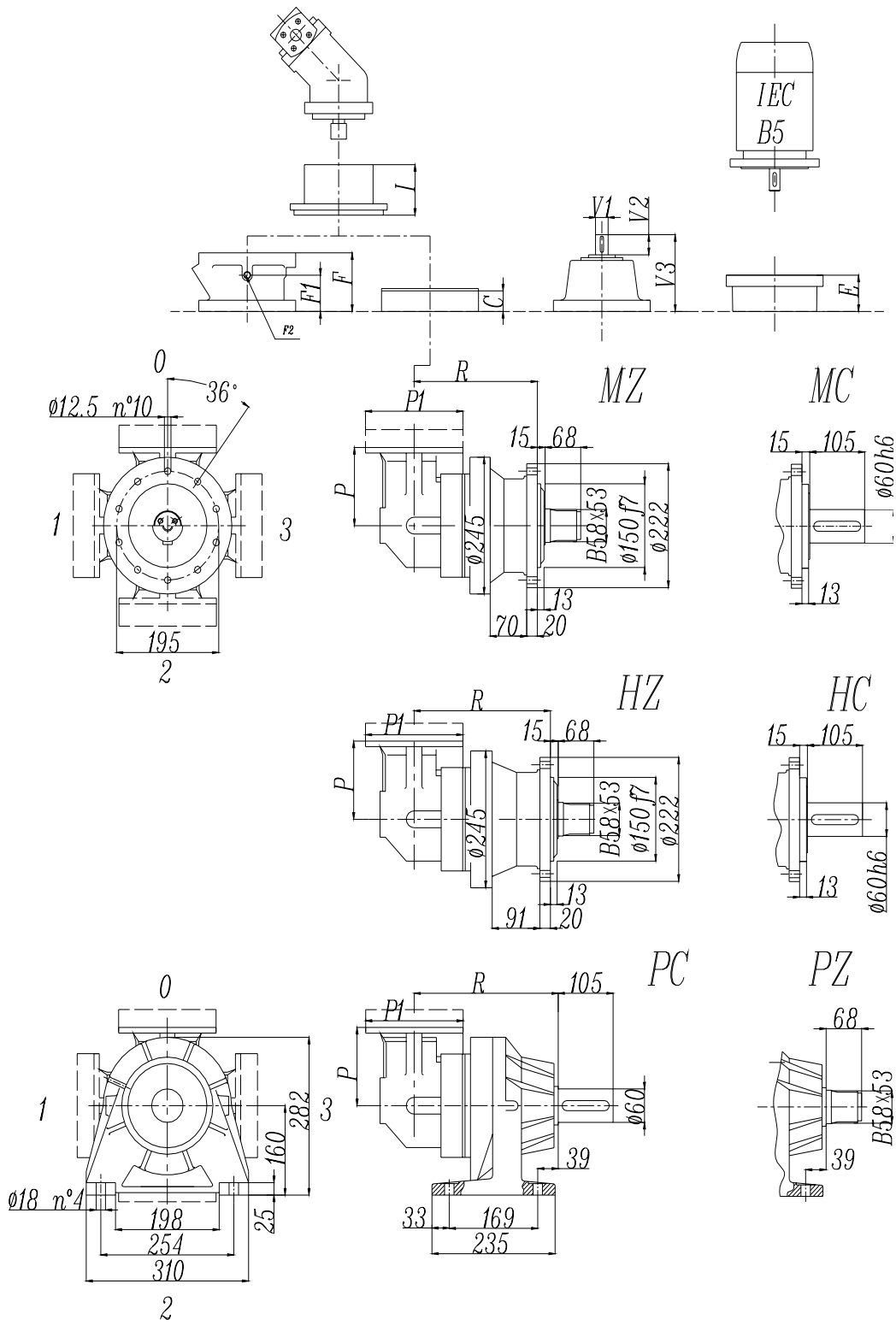

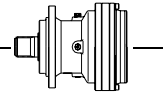

EP305R

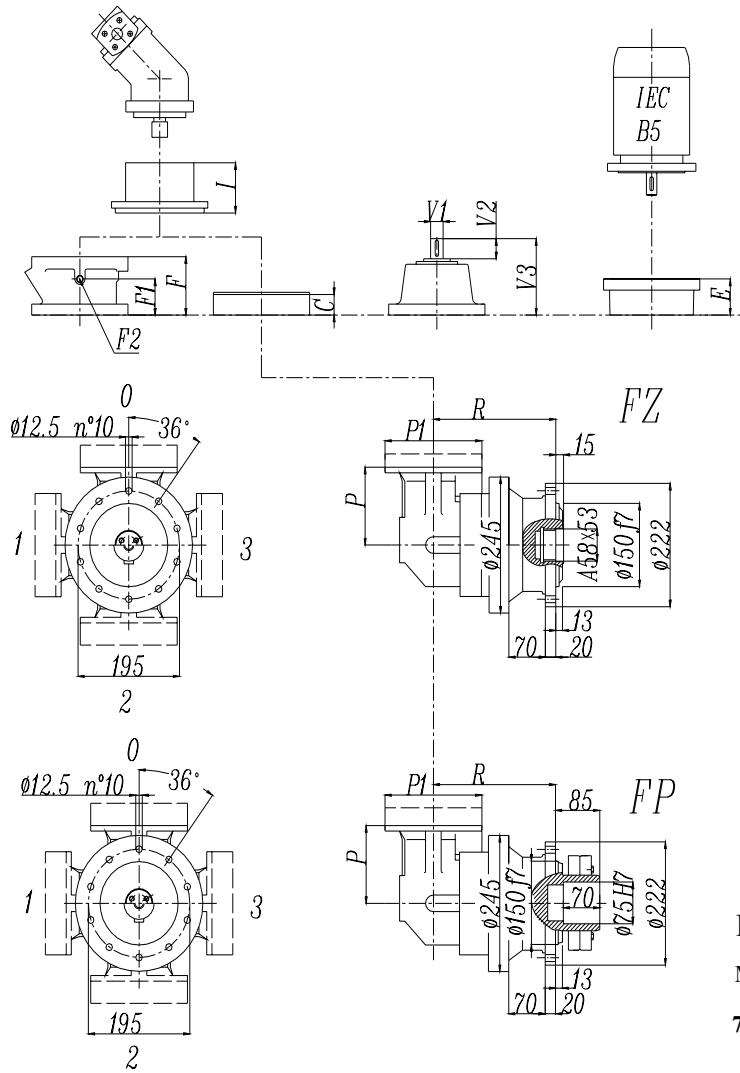

FP version
Max. transmissible
7000 N.m

	R				Ref. weight (without input) (Kg)				C	P	I	Brake				
	MZ MC	FZ FP	HZ HC	PC PZ	MZ MC	FZ FP	HZ HC	PC PZ				F	F1	F2	Type	Ref. Weight
305R2	239	239	264	279	51	51	55	60	37	140	According to hydraulic motor	105	65	1/4 G	4	15 Kg
305R3	304	304	329	344	49	49	53	58	37	122		105	65	1/4 G	4	
305R4	357	357	382	397	53	53	57	62	37	122		105	65	1/4 G	4	

	P1	E (IEC motor input)						
		IEC71	IEC80	IEC90	IEC100	IEC112	IEC132	
305R2	186	65	84	84	94	94	114	
305R3	186	65	84	84	94	94	114	
305R4	186	65	84	84	94	94	114	

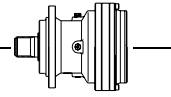

EP305L - EP305R

MC-HC

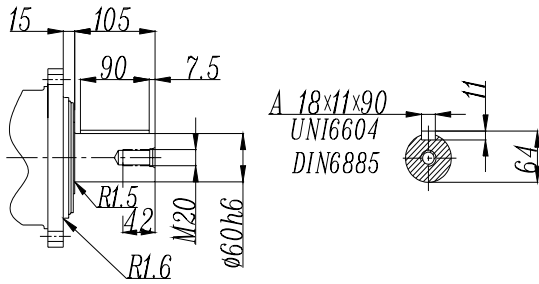

PC

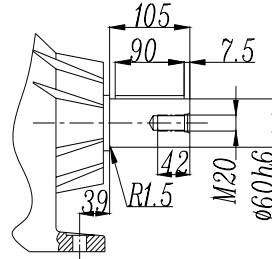

MZ-HZ

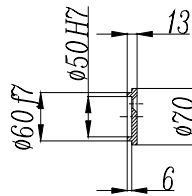
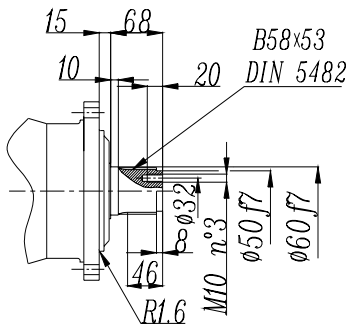

FZ

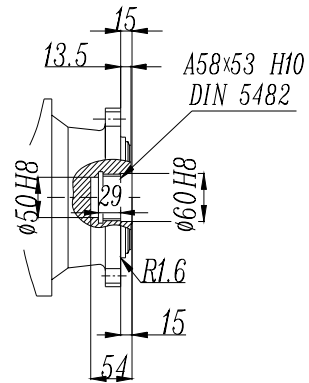

FP

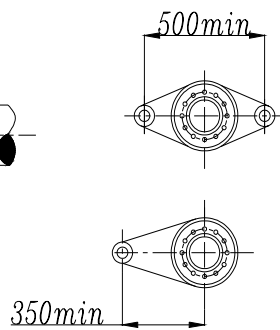
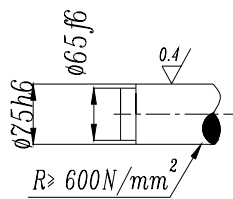
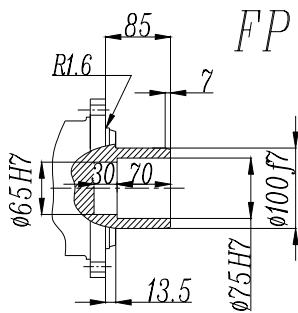

FP version

Max. transmissible

7000 N.m

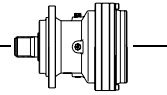

EP305L - EP305R

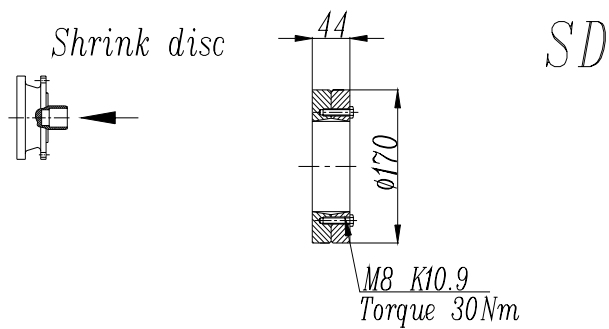
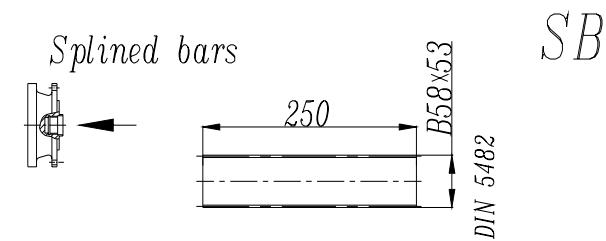
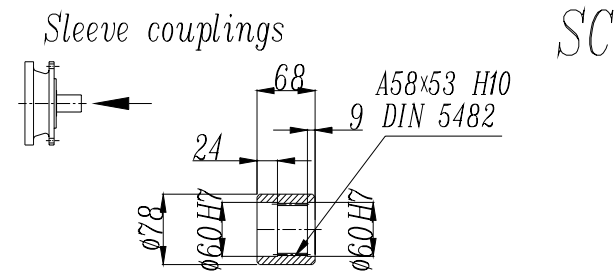
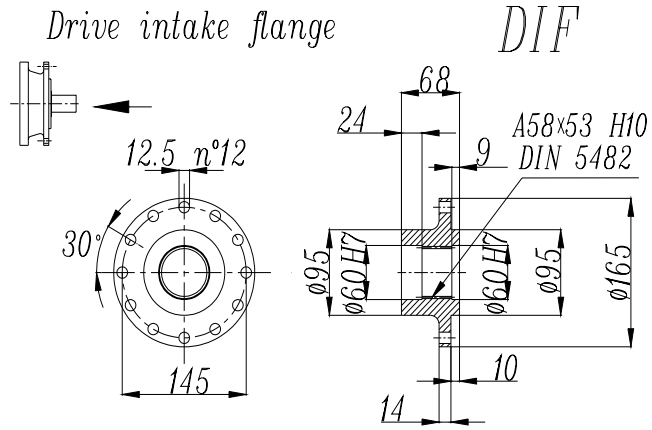

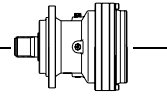

EP305L - EP305R

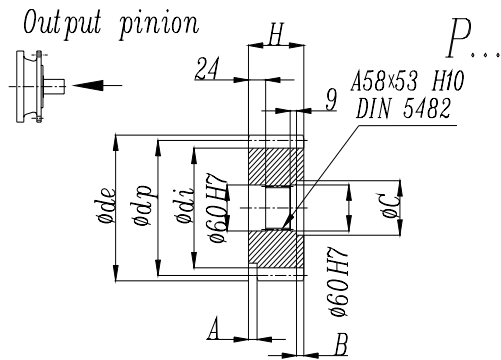

	m	z	x	dp	di	de	H	A	B	C
PCL1	5	19	0	95	82	104	77	12	9	72
PCL2	5	19	0	95	82	104	68	0	0	0
PCM	5	20	0	100	87.5	110	68	18	0	0
PCP	5	22	0	110	97.5	120	68	18	0	0
PDE	6	14	0.5000	84	75	99.6	68	0	0	0
PDI	6	18	0.5000	108	99	123.6	68	0	0	0
PDM	6	20	0.833	120	115	140	68	0	0	0
PFD	8	13	0.675	104	95	127.6	68	0	0	0
PFE1	8	14	0	112	92	126	68	0	0	0
PFE2	8	14	0	112	92	126	80	0	12	72
PFE	8	15	0	120	100	136	68	0	0	0
PFP	8	22	0	176	156	190	77	12	10	71
PHG	10	16	0.5000	160	145	188	75	0	7	72

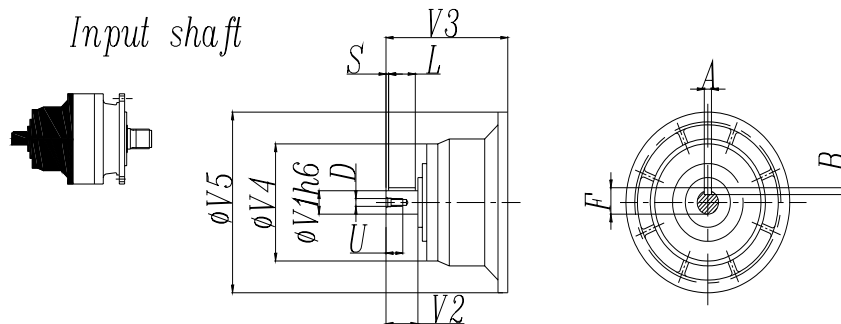

	CODE	V1	V2	V3	V4	V5	A	B	F	L	S	D	U
305L1	V05B	48	82	239	155	245	14	9	51.5	70	6	M16	36
305L2	V01A	24	36	137.5	120	186	8	7	27	30	3	M8	19
	V01B	38	58	158	120	186	10	8	41	50	4	M12	28
305L3	V01A	24	36	137.5	120	186	8	7	27	30	3	M8	19
	V01B	38	58	158	120	186	10	8	41	50	4	M12	28
305L4	V01A	24	36	137.5	120	186	8	7	27	30	3	M8	19
	V01B	38	58	158	120	186	10	8	41	50	4	M12	28
305R2-R3-R4	V01A	24	36	137.5	120	186	8	7	27	30	3	M8	19
	V01B	38	58	158	120	186	10	8	41	50	4	M12	28

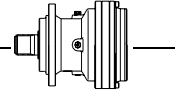

EP305L - EP305R

Permissible radial and axial loads on output shaft with Fh2 ($n_2 \cdot h=10\ 000$)

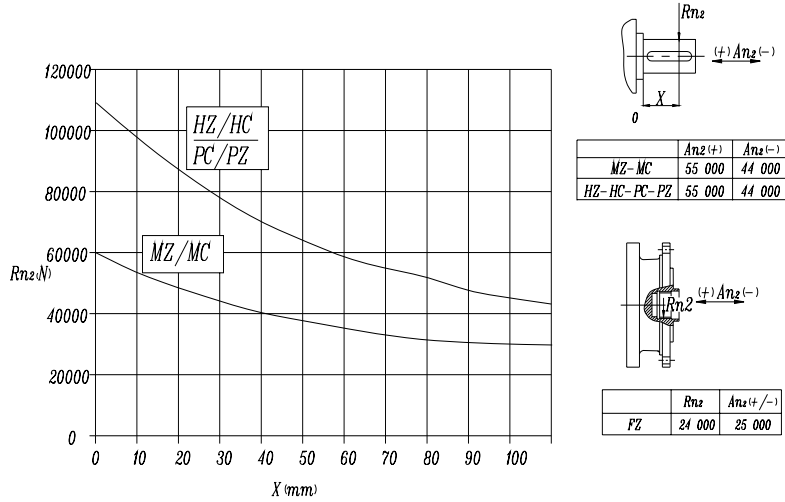

Load corrective factor fh2 on shafts	fh2= $n_2 \cdot h$		10 000	25 000	50 000	100 000	500 000	1 000 000
	fh2	MZ-MC-PC-PZ-FZ	1	0.74	0.58	0.46	0.27	0.21
		HZ-HC	1	0.76	0.61	0.50	0.31	0.25

Permissible radial loads on input shaft with Fh1 ($n_1 \cdot h=250\ 000$)

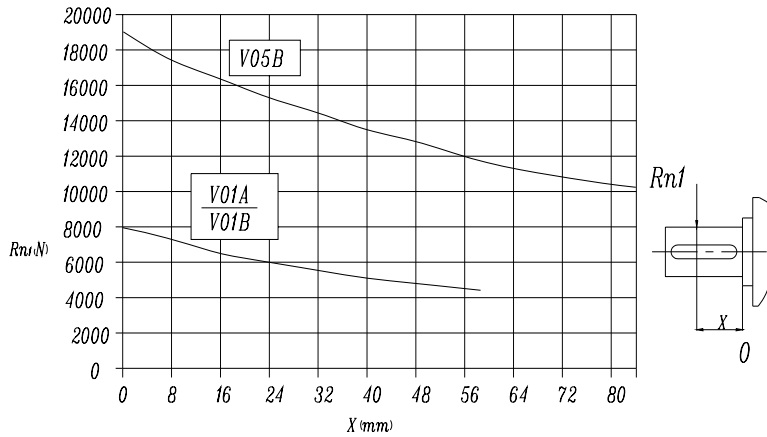

Load corrective factor fh1 on shafts	Fh1= $n_1 \cdot h$		250 000	500 000	1 000 000	2 00 000	5 000 000	10 000 000
	fh1		1	0.79	0.63	0.50	0.37	0.29

Planetary Gearbox

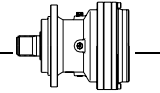

EP306L

M2'=8500N.m

	I 1:	Mn ₂ (N.m)						P ₁ (KW)	P _t (KW) (t _a =20°C (n ₁ =1500))	n ₁ (min ⁻¹)	n _{1max} (min ⁻¹)	M _b (N.m)	Brake type 制动器
		n ₂ .h 10000	n ₂ .h 25000	n ₂ .h 50000	n ₂ .h 100000	n ₂ .h 500000	n ₂ .h 1000000						
L1	3.7	10 000	9 600	9 400	9 300	6 000	4 850	75	18	1 500	3 000	3 200	6L
	4.2	10 000	9 600	9 400	9 300	6 000	4 850	75	18	1 500	3 000	3 200	6L
	4.9	9 500	8 500	7 800	7 800	5 700	4 600	75	18	1 500	3 000	2 600	6K
	5.8	8 500	7 200	6 500	6 500	5 700	4 650	75	18	1 500	3 000	2 100	6G
	7.1	7 000	5 900	5 500	5 500	4 700	3 850	60	18	1 500	3 000	1 500	6E
L2	13.5	10 000	9 600	9 400	9 300	6 000	4 850	40	13	1 750	3 500	1 000	5K
	17.6	10 000	9 600	9 400	9 300	6 000	4 850	40	13	1 750	3 500	1 000	5K
	21	10 000	9 600	9 400	9 300	6 000	4 850	40	13	1 750	3 500	800	5G
	24.7	9 500	8 500	7 800	7 800	5 700	4 600	30	13	1 750	3 500	400	5B
	28.9	8 500	7 200	6 500	6 500	5 700	4 650	26	13	1 750	3 500	400	5B
	32.2	8 500	7 200	6 500	6 500	5 700	4 650	24	13	1 750	3 500	400	5B
	39.5	8 500	7 200	6 500	6 500	5 700	4 650	22	13	1 750	3 500	400	5B
	48.4	7 000	5 900	5 500	5 500	4 700	3 850	16	13	1 750	3 500	400	5B
L3	45.7	10 000	9 600	9 400	9 300	6 000	4 850	21	7.5	1 750	3 500	330	4H
	59.6	10 000	9 600	9 400	9 300	6 000	4 850	16.5	7.5	1 750	3 500	260	4F
	78.2	10 000	9 600	9 400	9 300	6 000	4 850	13	7.5	1 750	3 500	260	4F
	102	10 000	9 600	9 400	9 300	6 000	4 850	11	7.5	1 750	3 500	160	4D
	143	9 500	8 500	7 800	7 800	5 700	4 600	9	7.5	1 750	3 500	160	4D
	167	8 500	7 200	6 500	6 500	5 700	4 650	6.9	7.5	1 750	3 500	100	4B
	186	8 500	7 200	6 500	6 500	5 700	4 650	6.2	7.5	1 750	3 500	100	4B
	232	8 500	7 200	6 500	6 500	5 700	4 650	5.1	7.5	1 750	3 500	100	4B
	284	8 500	7 200	6 500	6 500	5 700	4 650	4.2	7.5	1 750	3 500	50	4A
	348	7 000	5 900	5 500	5 500	4 700	3 850	2.8	7.5	1 750	3 500	50	4A
L4	203	10 000	9 600	9 400	9 300	6 000	4 850	8	6	1 750	3 500	100	4B
	264	10 000	9 600	9 400	9 300	6 000	4 850	6.2	6	1 750	3 500	100	4B
	344	10 000	9 600	9 400	9 300	6 000	4 850	4.9	6	1 750	3 500	50	4A
	451	10 000	9 600	9 400	9 300	6 000	4 850	3.8	6	1 750	3 500	50	4A
	586	10 000	9 600	9 400	9 300	6 000	4 850	2.9	6	1 750	3 500	50	4A
	731	10 000	9 600	9 400	9 300	6 000	4 850	2.4	6	1 750	3 500	50	4A
	822	9 500	8 500	7 800	7 800	5 700	4 600	1.7	6	1 750	3 500	50	4A
	1026	9 500	8 500	7 800	7 800	5 700	4 600	1.4	6	1 750	3 500	50	4A
	1202	8 500	7 200	6 500	6 500	5 700	4 650	1.1	6	1 750	3 500	50	4A
	1339	8 500	7 200	6 500	6 500	5 700	4 650	0.96	6	1 750	3 500	50	4A
	1671	8 500	7 200	6 500	6 500	5 700	4 650	0.8	6	1 750	3 500	50	4A
	2045	8 500	7 200	6 500	6 500	5 700	4 650	0.7	6	1 750	3 500	50	4A
2506	7 000	5 900	5 500	5 500	4 700	3 850	0.5	6	1 750	3 500	50	4A	

$$M_{2max}=1.2 \times Mn_2(n_2 \times h=10\ 000)$$

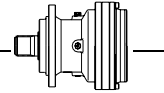

EP306R

M2'=8500N.m

	I 1:	Mn ₂ (N.m)						P ₁ (KW)	P _t (KW) (t _a =20°C) (n ₁ =1500)	n ₁ (min ⁻¹)	n _{1max} (min ⁻¹)	M _b (N.m)	Brake type
		n _{2,h} 10000	n _{2,h} 25000	n _{2,h} 50000	n _{2,h} 100000	n _{2,h} 500000	n _{2,h} 1000000						
R2	9.4	6 500	5 600	5 100	4 200	2 600	2 150	35	18	1 750	3 500	440	4L
	10.7	7 000	5 900	5 500	5 500	4 700	3 850	35	18	1 750	3 500	440	4L
	12.7	9 500	8 500	7 800	7 800	5 700	4 600	35	18	1 750	3 500	440	4L
	14.8	8 500	7 200	6 500	6 500	5 700	4 650	35	18	1 750	3 500	440	4L
	18.2	7 000	5 900	5 500	5 500	4 700	3 850	35	18	1 750	3 500	440	4L
R3	27.7	10 000	9 600	9 400	9 300	6 000	4 850	35	14	1 750	3 500	440	4L
	36	10 000	9 600	9 400	9 300	6 000	4 850	27	14	1 750	3 500	400	4K
	43	10 000	9 600	9 400	9 300	6 000	4 850	23	14	1 750	3 500	400	4K
	50.7	9 500	8 500	7 800	7 800	5 700	4 600	19	14	1 750	3 500	330	4H
	59.3	8 500	7 200	6 500	6 500	5 700	4 650	16.5	14	1 750	3 500	330	4H
	66	8 500	7 200	6 500	6 500	5 700	4 650	15	14	1 750	3 500	260	4F
	80.9	8 500	7 200	6 500	6 500	5 700	4 650	13	14	1 750	3 500	160	4D
	99.1	7 000	5 900	5 500	5 500	4 700	3 850	9	14	1 750	3 500	100	4B
R4	93.6	10 000	9 600	9 400	9 300	6 000	4 850	14	12	1 750	3 500	160	4D
	122	10 000	9 600	9 400	9 300	6 000	4 850	11.3	12	1 750	3 500	160	4D
	160	10 000	9 600	9 400	9 300	6 000	4 850	9.5	12	1 750	3 500	100	4B
	208	10 000	9 600	9 400	9 300	6 000	4 850	7.5	12	1 750	3 500	100	4B
	292	9 500	8 500	7 800	7 800	5 700	4 600	4.8	12	1 750	3 500	50	4A
	342	8 500	7 200	6 500	6 500	5 700	4 650	3.2	12	1 750	3 500	50	4A
	381	8 500	7 200	6 500	6 500	5 700	4 650	2.9	12	1 750	3 500	50	4A
	476	8 500	7 200	6 500	6 500	5 700	4 650	2.4	12	1 750	3 500	50	4A
	582	8 500	7 200	6 500	6 500	5 700	4 650	2	12	1 750	3 500	50	4A
	714	7 000	5 900	5 500	5 500	4 700	3 850	1.5	12	1 750	3 500	50	4A

$$M_{2max}=1.2 \times Mn_2(n_2 \times h=10\ 000)$$

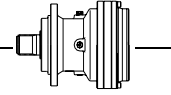

EP306L

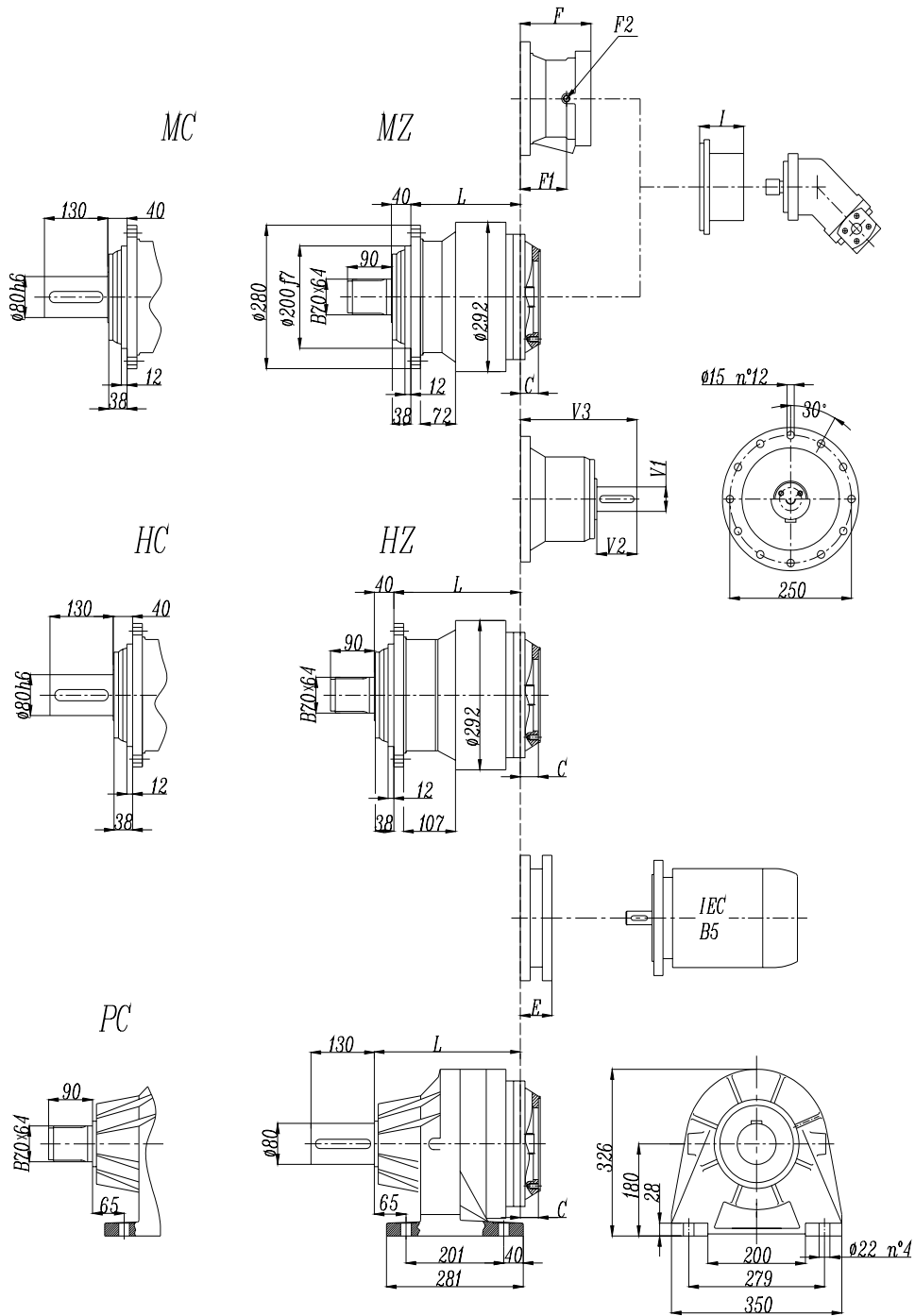

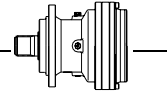

EP306L

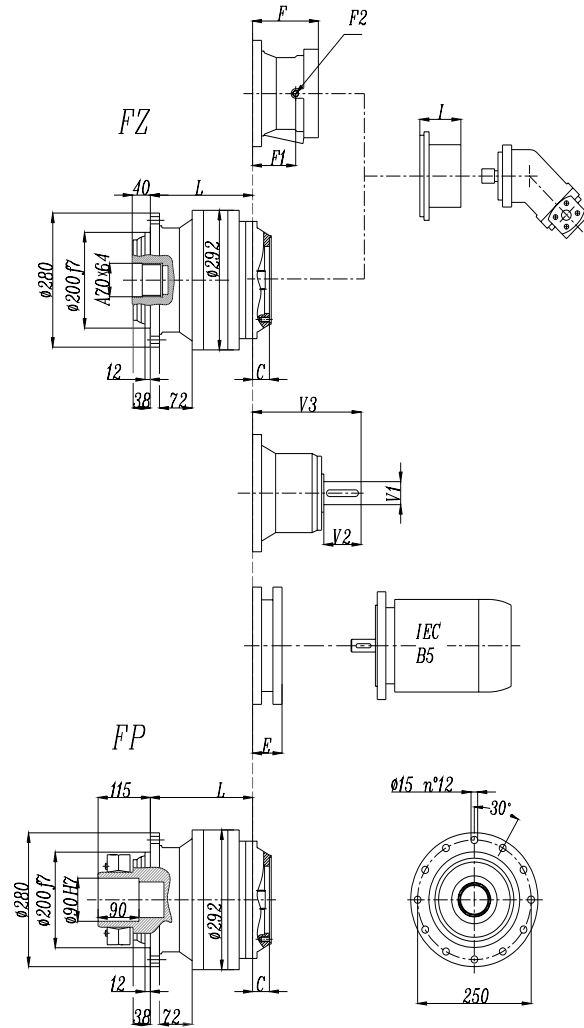

FP version

Max. transmissible

12000 N.m

	L				Ref. weight (without input) (Kg)				C	I	Brake				
	MZ MC	FZ FP	HZ HC	PC PZ	MZ MC	FZ FP	HZ HC	PC PZ			F	F1	F2	Type	Ref. Weight
306L1	160	160	195	235	65	65	70	80	45	According to hydraulic motor	195	147	1/4 G	6	35 Kg
306L2	229	229	264	304	74	74	79	89	37		145	95	1/4 G	5	22 Kg
306L3	282	282	317	357	78	78	83	93	37		105	65	1/4 G	4	15 Kg
306L4	335	335	370	410	82	82	87	97	37		105	65	1/4 G	4	15 Kg

	E (IEC motor input)												
	IEC 71	IEC 80	IEC 90	IEC 100	IEC 112	IEC 132	IEC 160	IEC 180	IEC 200	IEC 225	IEC 250		
306L1							152	152	182	212	193		
306L2	65	84	84	94	94	114	144						
306L3	65	84	84	94	94	114	144						
306L4	65	84	84	94	94	114	144						

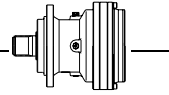

EP306R

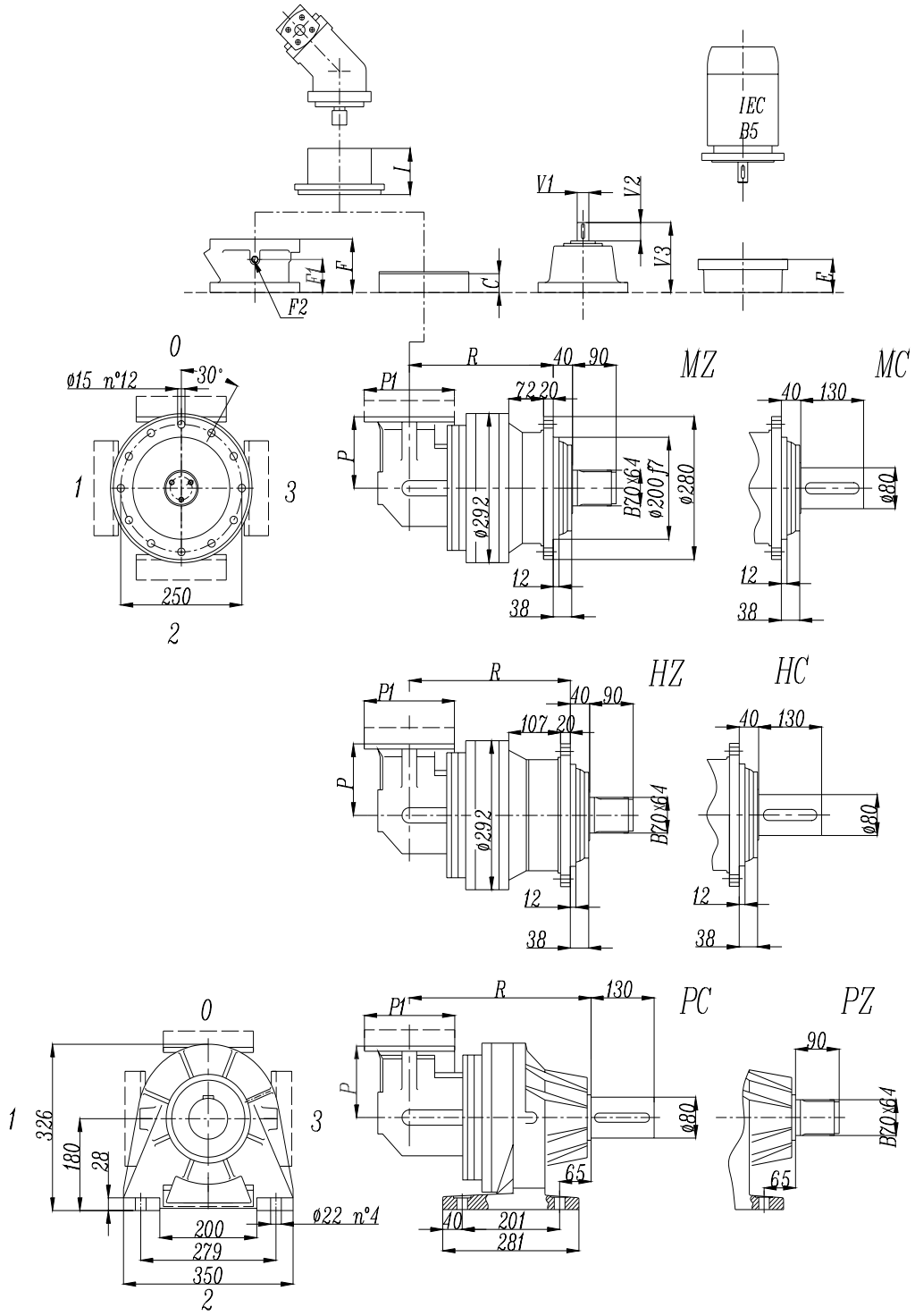

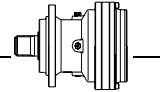

EP306R

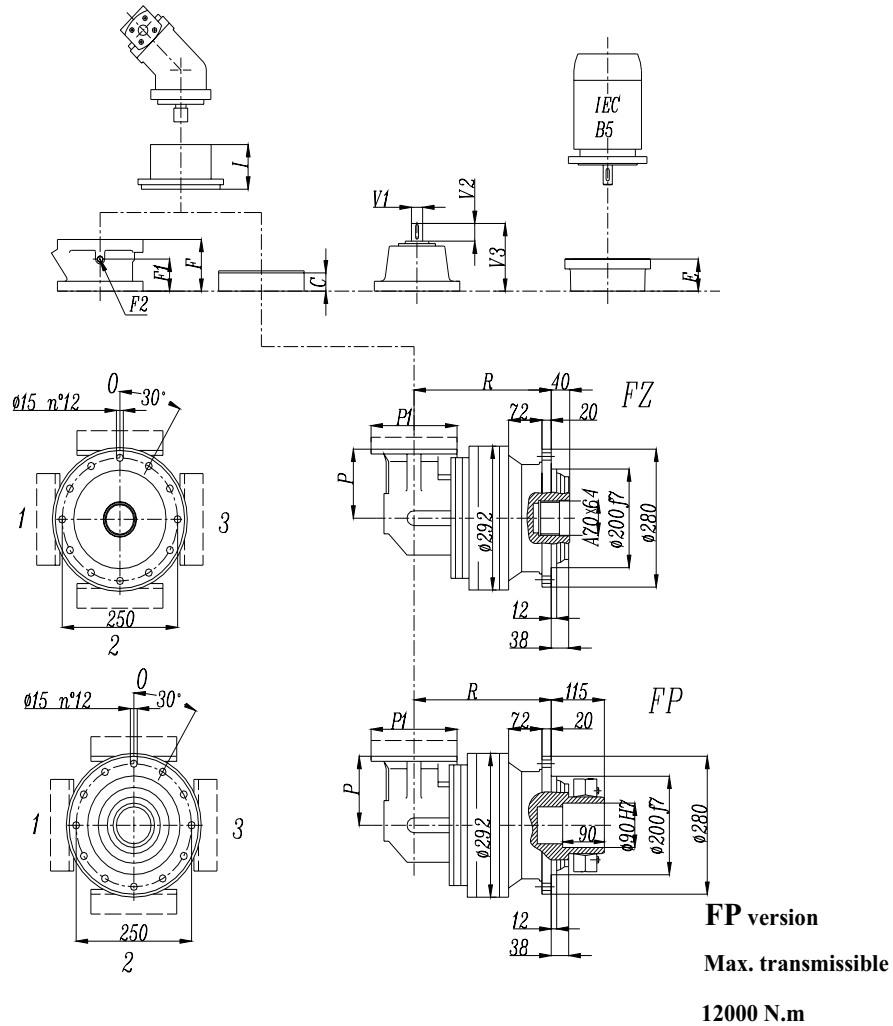

	R				Ref. weight (without input) (Kg)				C	P	I	Brake				Ref. Weight
	MZ MC	FZ FP	HZ HC	PC PZ	MZ MC	FZ FP	HZ HC	PC PZ				F	F1	F2	Type	
306R2	297	297	332	372	89	89	94	104	37	140	According to hydraulic motor	105	65	1/4 G	4	15 Kg
306R3	321	321	356	396	85	85	90	100	37	140		105	65	1/4 G	4	
306R4	374	374	409	449	79	79	84	94	37	122		105	65	1/4 G	4	

	P1	E (IEC motor input)						
		IEC71	IEC80	IEC90	IEC100	IEC112	IEC132	IEC160
306R2	186	65	84	84	94	94	114	144
306R3	186	65	84	84	94	94	114	144
306R4	186	65	84	84	94	94	114	144

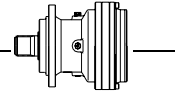

EP306L - EP306R

MC-HC

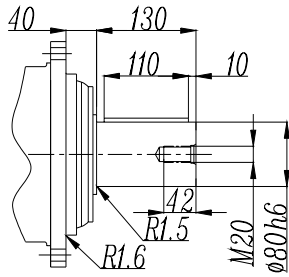

A 22x14x10
UNI 6604
DIN 6885

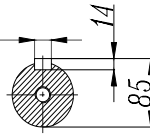

PC

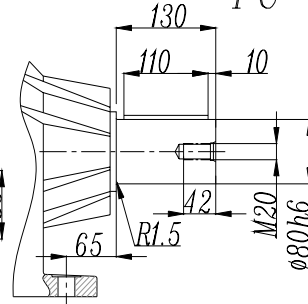

MZ-HZ

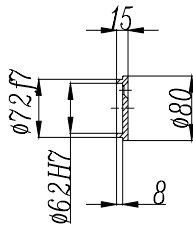
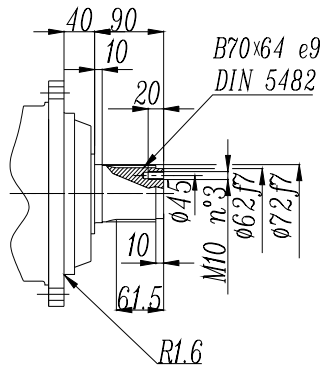

FZ

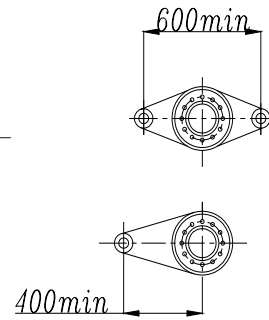
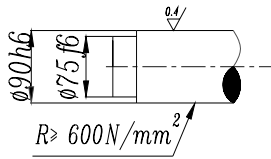
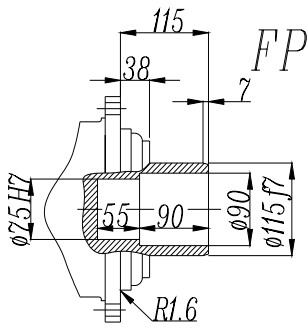
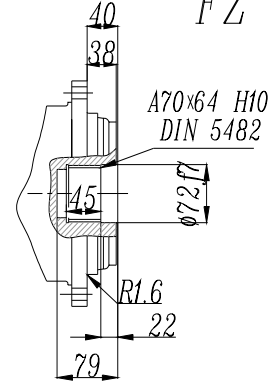

FP version

Max. transmissible

12000 N.m

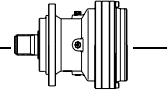

EP306L - EP306R

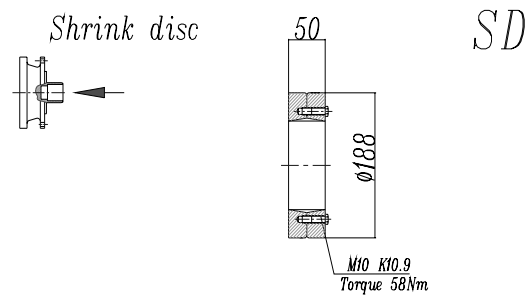
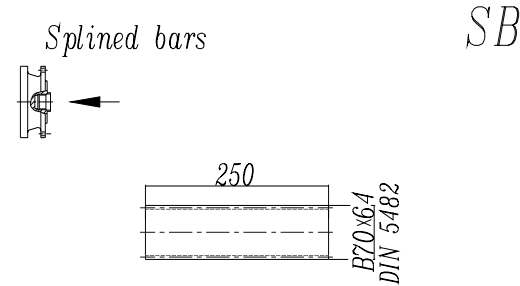
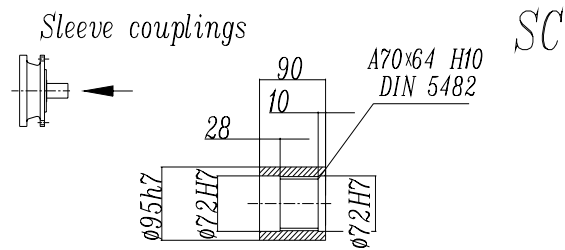
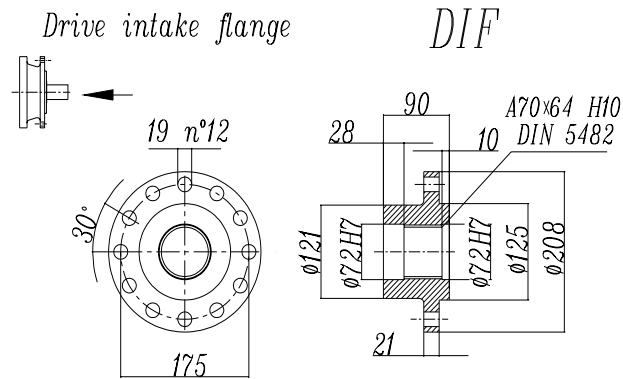

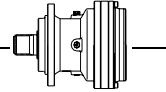

EP306L - EP306R

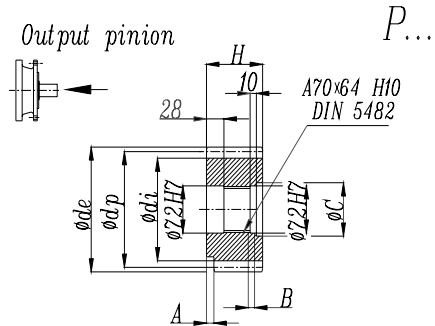

	m	z	x	dp	di	de	H	A	B	C
PFE1	8	15	0	120	100	134	90	0	0	0
PFE2	8	15	0.5000	120	108	141	90	0	0	0
PHB	10	11	0.500	110	95	136	90	10	0	0
PHC1	10	12	0.450	120	104	145	90	0	0	0
PHC2	10	12	0.320	120	100	144.2	90	0	0	0
PHC3	10	12	0.350	120	101	144	90	0	0	0
PHD1	10	13	0.950	130	124	165	90	0	0	0
PHD2	10	13	0.500	130	115	159	90	0	0	0
PHE1	10	14	0	140	115	160	90	0	0	0
PHE2	10	14	0.500	140	125	166	90	0	0	0
PHF	10	15	0	150	127	167	90	24	0	0
PHH	10	17	0.480	170	154	197.5	90	10	0	0
PHM	10	20	0	200	175	220	90	10	0	0

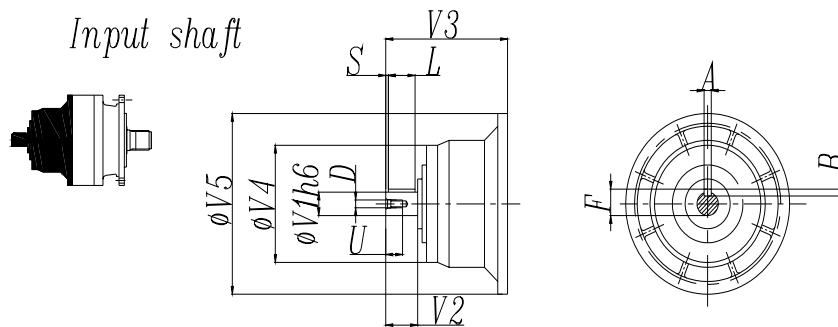

	CODE	V1	V2	V3	V4	V5	A	B	F	L	S	D	U
306L1	V06B	60	105	307	155	292	18	11	64	90	7.5	M16	36
306L2	V05B	48	82	239	155	245	14	9	51.5	70	6	M16	36
306L3	V01A	24	36	137.5	120	186	8	7	27	30	3	M8	19
	V01B	38	58	158	120	186	10	8	41	50	4	M12	28
306L4	V01A	24	36	137.5	120	186	8	7	27	30	3	M8	19
	V01B	38	58	158	120	186	10	8	41	50	4	M12	28
306R2-R3-R4	V01A	24	36	137.5	120	186	8	7	27	30	3	M8	19
	V01B	38	58	158	120	186	10	8	41	50	4	M12	28

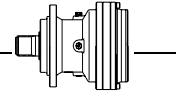

EP306L - EP306R

Permissible radial and axial loads on output shaft with Fh2 ($n_2 \cdot h=10\ 000$)

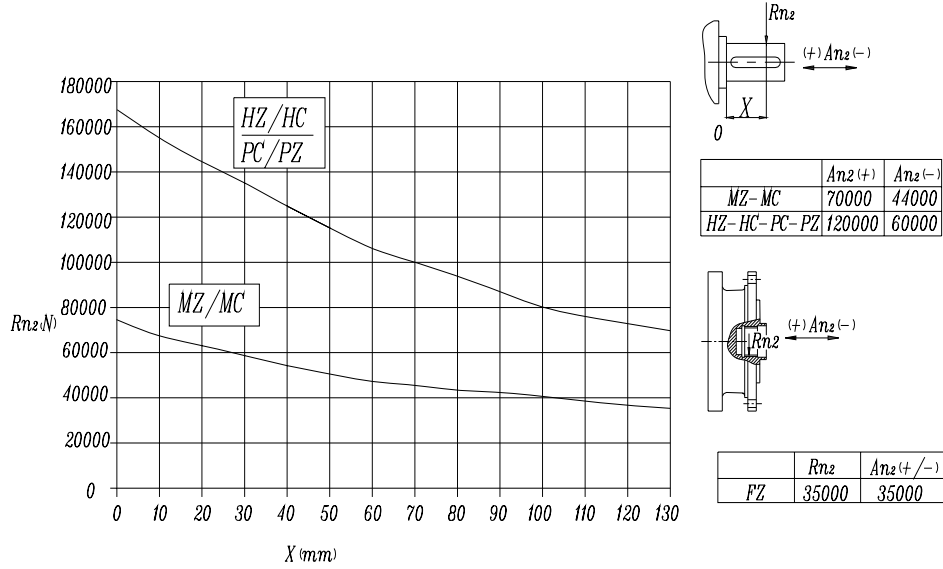

Load corrective factor fh2 on shafts	fh2= $n_2 \cdot h$						
	10 000	25 000	50 000	100 000	500 000	1 000 000	
MZ-MC-PC-PZ-FZ	1	0.74	0.58	0.46	0.27	0.21	
HZ-HC	1	0.76	0.61	0.50	0.31	0.25	

Permissible radial loads on input shaft with Fh1 ($n_1 \cdot h=250\ 000$)

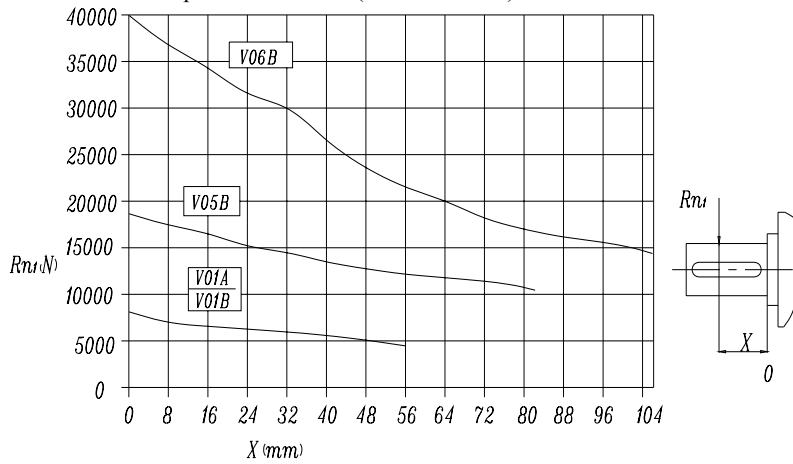

Load corrective factor fh1 on shafts	Fh1= $n_1 \cdot h$						
	250 000	500 000	1 000 000	2 000 000	5 000 000	10 000 000	
fh1	1	0.79	0.63	0.50	0.37	0.29	

Planetary Gearbox

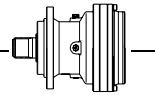

EP307L

M2'=12500N.m

	I 1:	Mn ₂ (N.m)						P ₁ (KW)	P _t (KW) (t _a =20°C) (n ₁ =1500)	n ₁ (min ⁻¹)	n _{1max} (min ⁻¹)	M _b (N.m)	Brake type
		n ₂ .h 10000	n ₂ .h 25000	n ₂ .h 50000	n ₂ .h 100000	n ₂ .h 500000	n ₂ .h 1000000						
L1	3.4	15 000	13 800	12 900	12 500	7 900	6 400	100	22	1 500	2 500	3 200	6L
	4.4	15 000	13 800	12 900	12 500	7 900	6 400	100	22	1 500	2 500	3 200	6L
	5.3	14 000	12 000	10 700	10 500	7 700	6 200	100	22	1 500	2 500	3 200	6L
	6.2	11 000	9 600	8 700	8 700	7 700	6 200	100	22	1 500	2 500	2 100	6K
L2	12.6	15 000	13 800	12 900	12 500	7 900	6 400	60	18	1 750	3 500	1 000	5K
	16.1	15 000	13 800	12 900	12 500	7 900	6 400	60	18	1 750	3 500	1 000	5K
	18.5	15 000	13 800	12 900	12 500	7 900	6 400	60	18	1 750	3 500	1 000	5K
	22	15 000	13 800	12 900	12 500	7 900	6 400	55	18	1 750	3 500	1 000	5K
	26.3	14 000	12 000	10 700	10 500	7 700	6 200	50	18	1 750	3 500	800	5G
	29.2	14 000	12 000	10 700	10 500	7 700	6 200	45	18	1 750	3 500	630	5E
	35.8	14 000	12 000	10 700	10 500	7 700	6 200	37	18	1 750	3 500	500	5C
	42.5	11 000	9 600	8 700	8 700	7 700	6 200	32	18	1 750	3 500	400	5B
	L3	42.5	15 000	13 800	12 900	12 500	7 900	6 400	35	11	1 750	3 500	400
54.6		15 000	13 800	12 900	12 500	7 900	6 400	28	11	1 750	3 500	330	4H
62.5		15 000	13 800	12 900	12 500	7 900	6 400	25	11	1 750	3 500	330	4H
82.1		15 000	13 800	12 900	12 500	7 900	6 400	20	11	1 750	3 500	260	4F
107		15 000	13 800	12 900	12 500	7 900	6 400	16	11	1 750	3 500	160	4D
127		15 000	13 800	12 900	12 500	7 900	6 400	14	11	1 750	3 500	160	4D
151		14 000	12 000	10 700	10 500	7 700	6 200	11.8	11	1 750	3 500	160	4D
169		14 000	12 000	10 700	10 500	7 700	6 200	10	11	1 750	3 500	100	4B
211		14 000	12 000	10 700	10 500	7 700	6 200	8	11	1 750	3 500	100	4B
L4	258	14 000	12 000	10 700	10 500	7 700	6 200	7	11	1 750	3 500	100	4B
	306	11 000	9 600	8 700	8 700	7 700	6 200	5	11	1 750	3 500	50	4A
	278	15 000	13 800	12 900	12 500	7 900	6 400	6	7.5	1 750	3 500	50	4A
	365	15 000	13 800	12 900	12 500	7 900	6 400	5	7.5	1 750	3 500	50	4A
	474	15 000	13 800	12 900	12 500	7 900	6 400	4	7.5	1 750	3 500	50	4A
	591	15 000	13 800	12 900	12 500	7 900	6 400	3.3	7.5	1 750	3 500	50	4A
	768	15 000	13 800	12 900	12 500	7 900	6 400	2.6	7.5	1 750	3 500	50	4A
	914	15 000	13 800	12 900	12 500	7 900	6 400	2.2	7.5	1 750	3 500	50	4A
	1090	14 000	12 000	10 700	10 500	7 700	6 200	2	7.5	1 750	3 500	50	4A
	1215	14 000	12 000	10 700	10 500	7 700	6 200	1.7	7.5	1 750	3 500	50	4A
	1516	14 000	12 000	10 700	10 500	7 700	6 200	1.2	7.5	1 750	3 500	50	4A
1856	14 000	12 000	10 700	10 500	7 700	6 200	1	7.5	1 750	3 500	50	4A	
2202	11 000	9 600	8 700	8 700	7 700	6 200	0.8	7.5	1 750	3 500	50	4A	

$$M_{2max}=1.2 \times Mn2(n2 \times h=10\ 000)$$

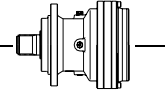

EP307R

M2'=12500N.m

	I 1:	Mn ₂ (N.m)						P ₁ (KW)	P _t (KW) (t _a =20°C) (n ₁ =1500)	n ₁ (min ⁻¹)	n _{1max} (min ⁻¹)	M _b (N.m)	Brake type
		n _{2,h} 10000	n _{2,h} 25000	n _{2,h} 50000	n _{2,h} 100000	n _{2,h} 500000	n _{2,h} 1000000						
R2	13	9 100	8 500	7 600	6 800	5 500	4 400	60	35	1 750	3 500	1000	5K
	16.7	11 000	9 800	8 900	12 500	7 900	6 400	50	35	1 750	3 500	800	5G
	19.9	14 000	12 000	10 700	10 500	7 700	6 200	45	35	1 750	3 500	800	5G
	23.6	11 000	9 600	8 700	8 700	7 700	6 200	42	35	1 750	3 500	800	5G
R3	32.2	9 100	8 500	7 600	6 800	5 500	4 400	30	20	1 750	3 500	400	4K
	41.3	11 000	9 800	8 900	12 500	7 900	6 400	28	20	1 750	3 500	400	4K
	47.4	14 000	12 000	10 700	10 500	7 700	6 200	25	20	1 750	3 500	400	4K
	56.4	15 000	13 800	12 900	12 500	7 900	6 400	22	20	1 750	3 500	330	4H
	67.3	14 000	12 000	10 700	10 500	7 700	6 200	20	20	1 750	3 500	330	4H
	75	14 000	12 000	10 700	10 500	7 700	6 200	18	20	1 750	3 500	260	4F
	91.8	14 000	12 000	10 700	10 500	7 700	6 200	15	20	1 750	3 500	260	4F
	109	11 000	9 600	8 700	8 700	7 700	6 200	12	20	1 750	3 500	160	4D
R4	112	15 000	13 800	12 900	12 500	7 900	6 400	12	14	1 750	3 500	160	4D
	128	15 000	13 800	12 900	12 500	7 900	6 400	11	14	1 750	3 500	160	4D
	168	15 000	13 800	12 900	12 500	7 900	6 400	9	14	1 750	3 500	160	4D
	219	15 000	13 800	12 900	12 500	7 900	6 400	7	14	1 750	3 500	100	4B
	260	15 000	13 800	12 900	12 500	7 900	6 400	6	14	1 750	3 500	100	4B
	310	14 000	12 000	10 700	10 500	7 700	6 200	5.5	14	1 750	3 500	100	4B
	346	14 000	12 000	10 700	10 500	7 700	6 200	5	14	1 750	3 500	100	4B
	433	14 000	12 000	10 700	10 500	7 700	6 200	4	14	1 750	3 500	50	4A
	529	14 000	12 000	10 700	10 500	7 700	6 200	3.3	14	1 750	3 500	50	4A
	627	11 000	9 600	8 700	8 700	7 700	6 200	2.5	14	1 750	3 500	50	4A
M_{2max}=1.2×Mn₂(n₂×h=10 000)													

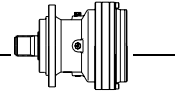

EP307L

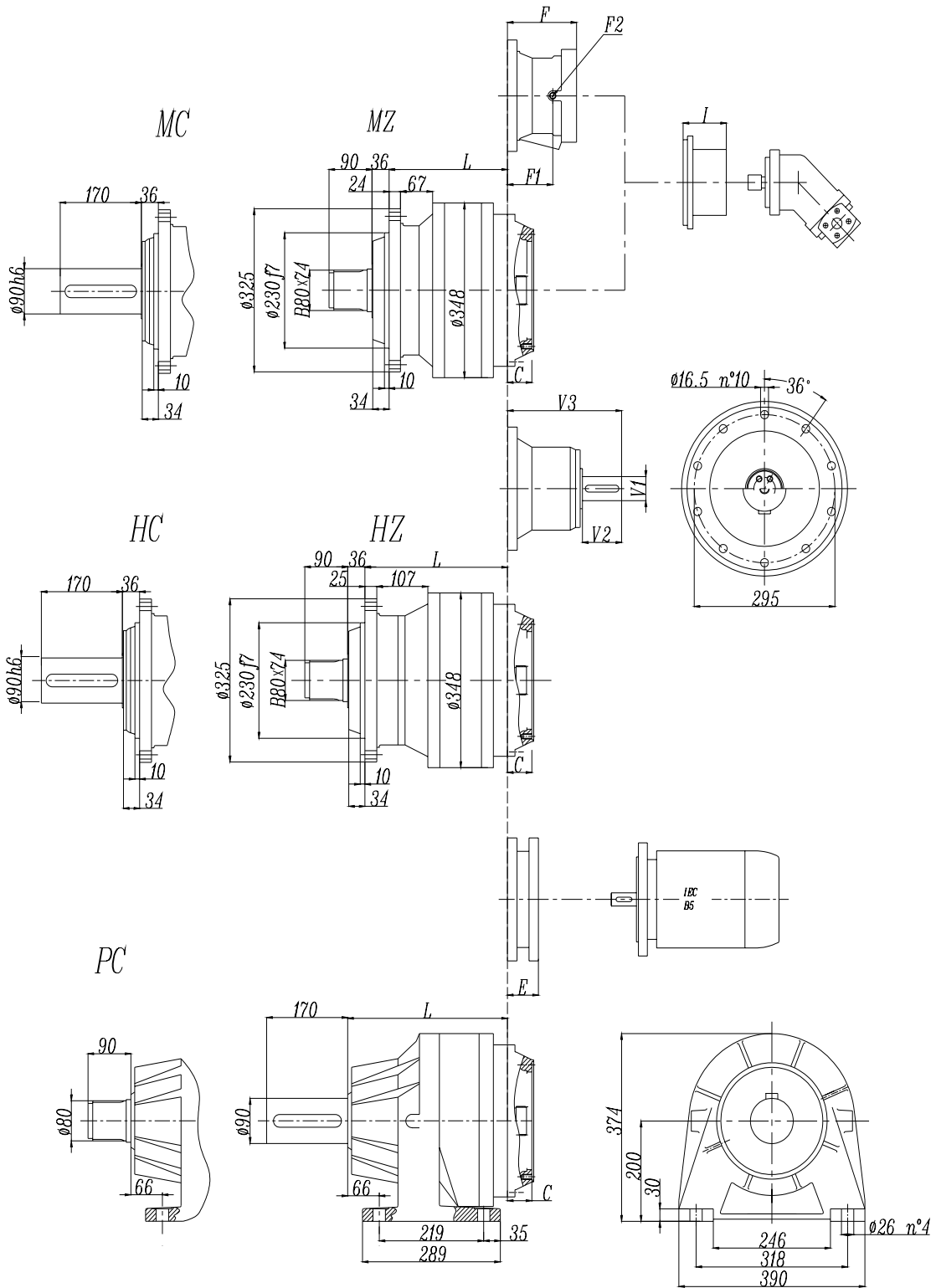

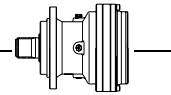

EP307L

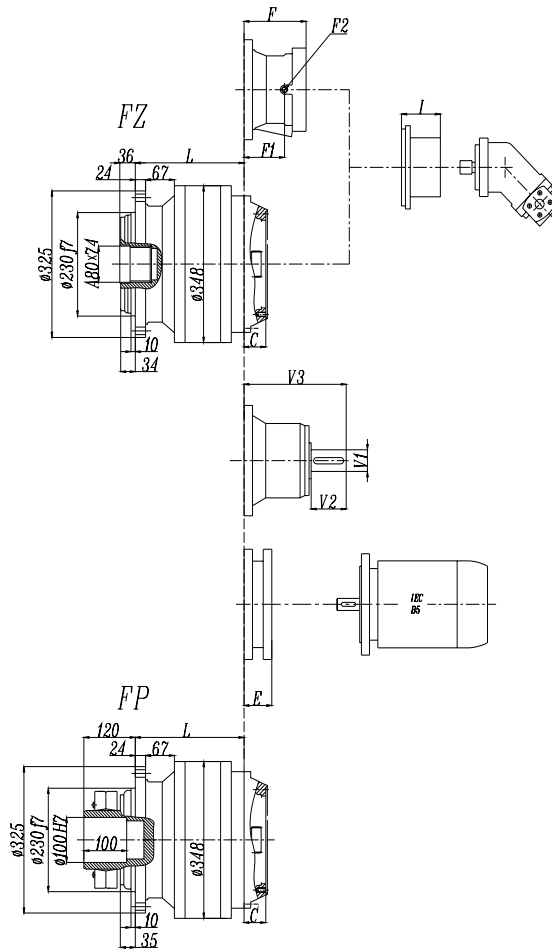

FP version

Max. transmissible

18000 N.m

	L				Ref. weight (without input) (Kg)				C	I	Brake				
	MZ MC	FZ FP	HZ HC	PC PZ	MZ MC	FZ FP	HZ HC	PC PZ			F	F1	F2	Type	Ref. Weight
307L1	165	165	210	246	95	85	105	120	51	According to hydraulic motor	201	153	1/4 G	6	38 Kg
307L2	258	258	303	339	107	97	117	132	37		145	95	1/4 G	5	22 Kg
307L3	323	323	368	404	114	104	124	139	37		105	65	1/4 G	4	15 Kg
307L4	376	376	421	457	118	108	128	143	37		105	65	1/4 G	4	15 Kg

	E (IEC motor input)													
	IEC 71	IEC 80	IEC 90	IEC 100	IEC 112	IEC 132	IEC 160	IEC 180	IEC 200	IEC 225	IEC 250			
307L1								195	186	216	216			
307L2	65	84	84	94	94	114	144							
307L3	65	84	84	94	94	114	144							
307L4	65	84	84	94	94	114	144							

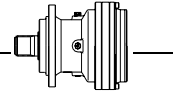

EP307R

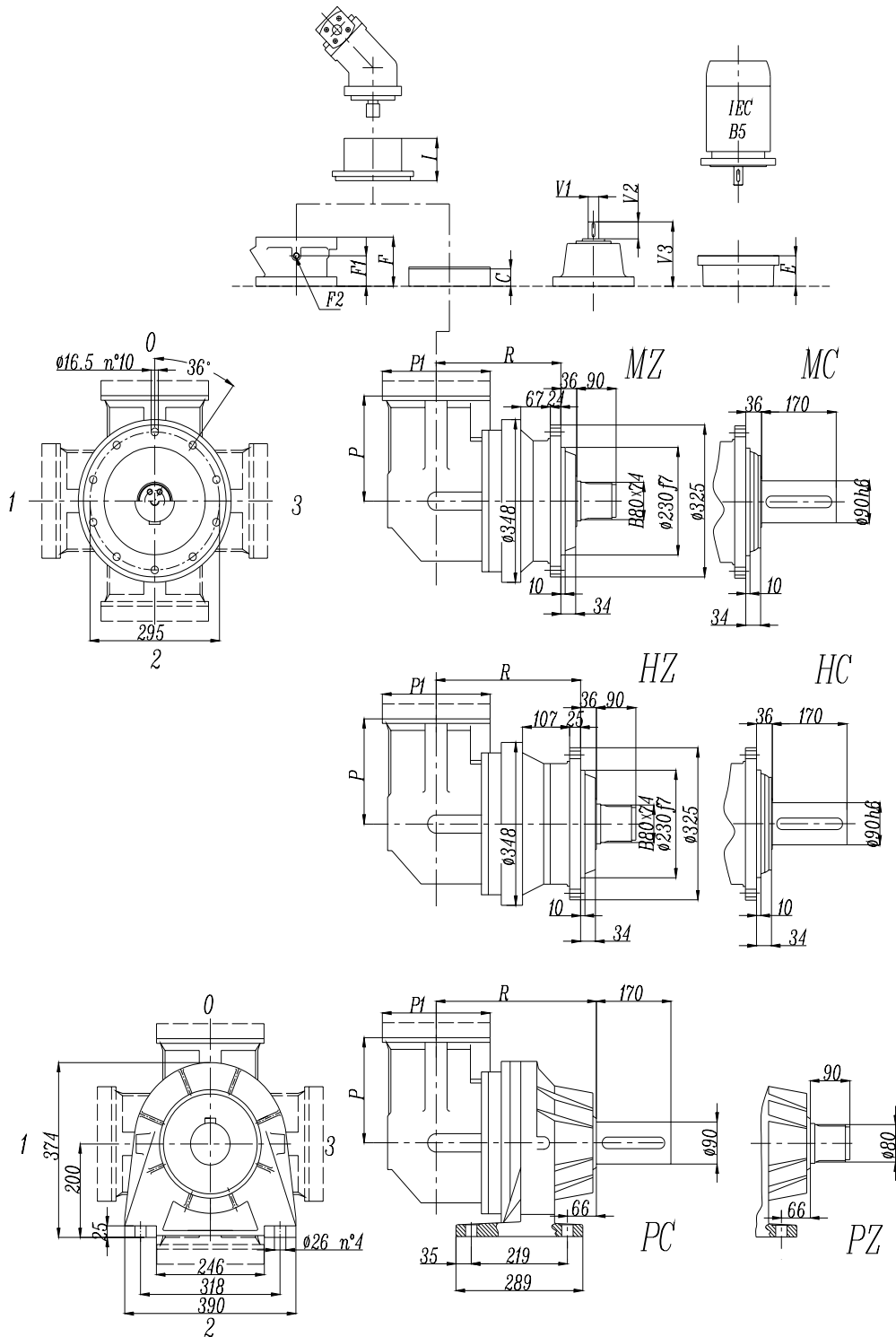

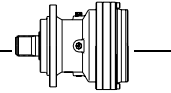

EP307R

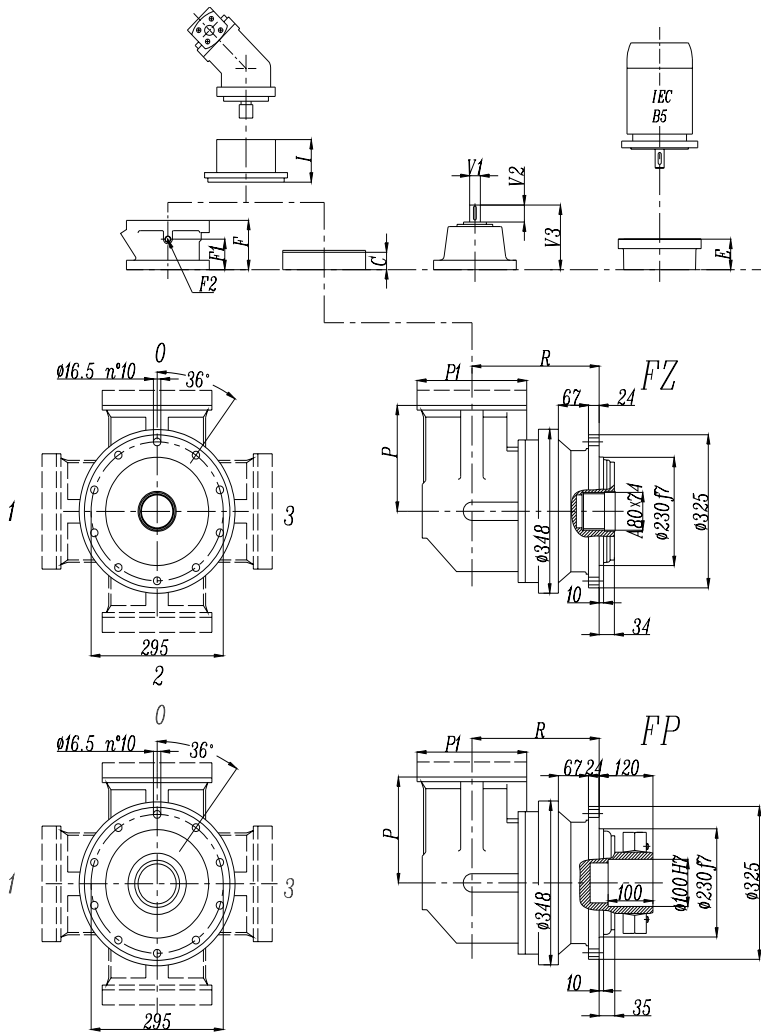

FP version
Max. transmissible
18000 N.m

	R				Ref. weight (without input) (Kg)				C	P	I	Brake				
	MZ MC	FZ FP	HZ HC	PC PZ	MZ MC	FZ FP	HZ HC	PC PZ				F	F1	F2	Type	Ref. Weight 15 Kg
307R2	284	284	329	365	145	135	155	170	37	225	According to hydraulic motor	145	95	1/4 G	4	22
307R3	350	350	395	431	127	117	137	152	37	140		105	65	1/4 G	4	15
307R4	415	415	460	496	128	118	138	153	37	122		105	65	1/4 G	4	15

	P1	E (IEC motor input)									
		IEC 71	IEC 80	IEC 90	IEC 100	IEC 112	IEC 132	IEC 160	IEC 180	IEC 200	
307R2	245	65	84	84	94	94	114	144	144	174	
307R3	186	65	84	84	94	94	114	144			
307R4	186	65	84	84	94	94	114	144			

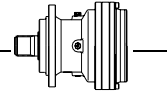

EP307L - EP307R

MC-HC

PC

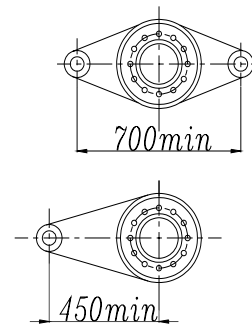
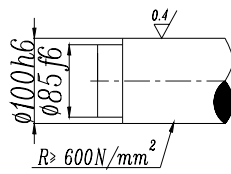
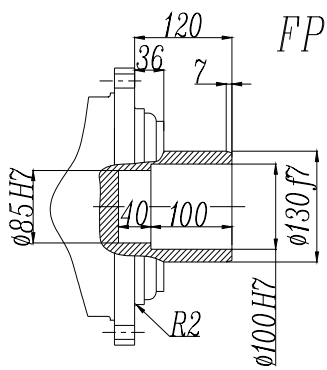
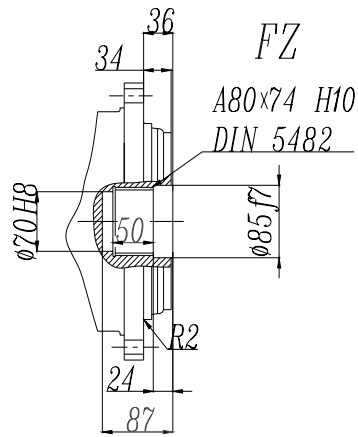
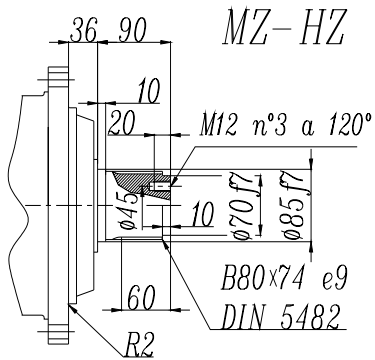
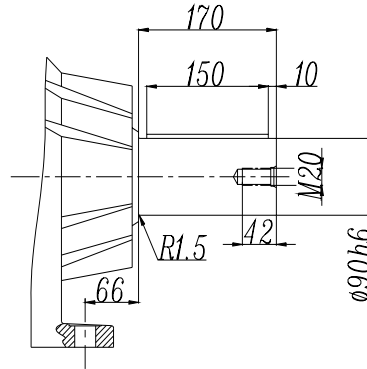
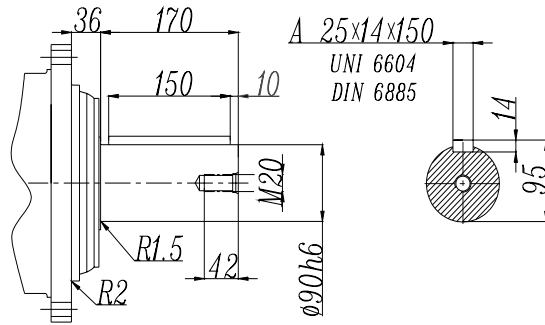

FP version

Max. transmissible

18000 N.m

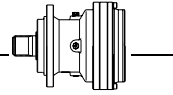

EP307L - EP307R

Drive intake flange

DIF

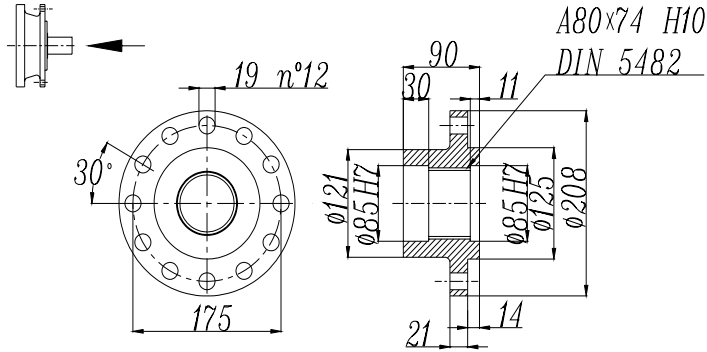

Sleeve couplings

SC

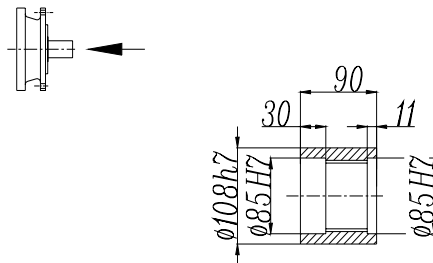

Splined bars

SB

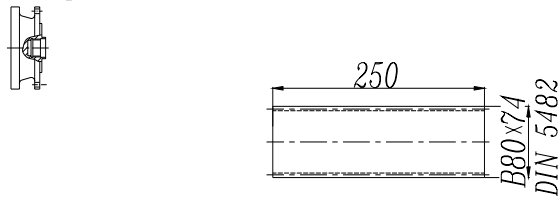

Shrink disc

SD

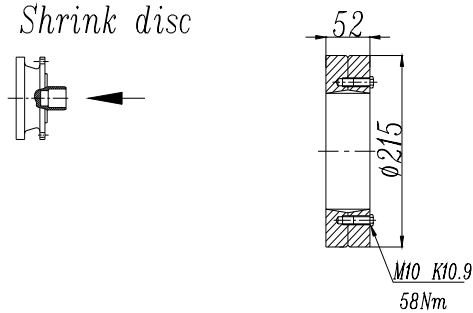

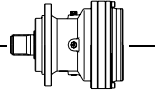

EP307L - EP307R

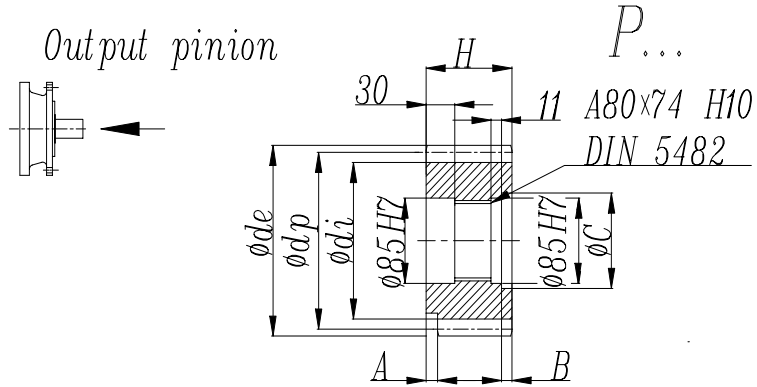

	m	z	x	dp	di	de	H	A	B	C
PFG	8	16	0.5000	128	117	149.5	90	0	0	0
PHC	10	12	0.4500	120	104	145	90	0	0	0
PHE	10	14	0.320	140	121	162.5	116	13	26	95
PHF	10	15	0.150	150	130	171.5	107	20	17	100
PHG	10	16	0.500	160	145	186	90	10	0	0
PHH1	10	17	0	170	145	190	90	0	0	0
PHH2	10	17	0.500	170	154	198	90	0	0	0
PLD	12	13	0.500	156	138	192	102	0	12	95
PLE	12	14	0.500	168	150	199.2	90	0	0	0
PLI	12	18	0.500	216	198	249.6	107	7	17	95
PLT	12	26	0	312	282	336	90	0	0	0

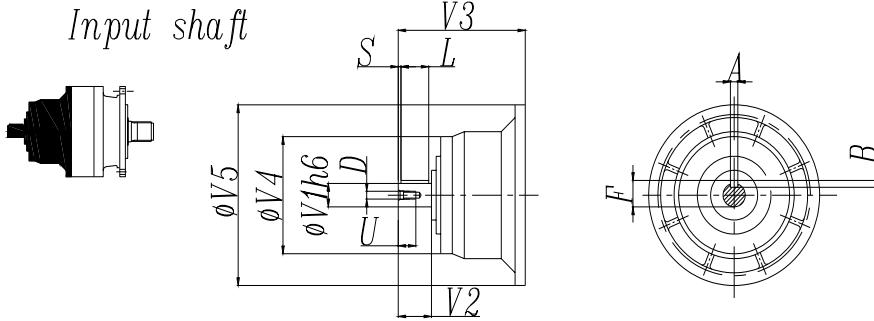

	CODE	V1	V2	V3	V4	V5	A	B	F	L	S	D	U
307L1	V07B	80	130	315	200	345	22	14	85	110	10	M16	36
	V07A	60	105	313	155	345	18	11	64	90	7.5	M16	36
307L2	V05B	48	82	239	155	245	14	9	51.5	70	6	M16	36
307L3	V01A	24	36	137.5	120	186	8	7	27	30	3	M8	19
	V01B	38	58	158	120	186	10	8	41	50	4	M12	28
307L4	V01A	24	36	137.5	120	186	8	7	27	30	3	M8	19
	V01B	38	58	158	120	186	10	8	41	50	4	M12	28
307R2	V05B	48	82	239	155	245	14	9	51.5	70	6	M16	36
307 R3-R4	V01A	24	36	137.5	120	186	8	7	27	30	3	M8	19
	V01B	38	58	158	120	186	10	8	41	50	4	M12	28

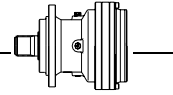

EP307L - EP307R

Permissible radial and axial loads on output shaft with Fh2 ($n_2 \cdot h=10\ 000$)

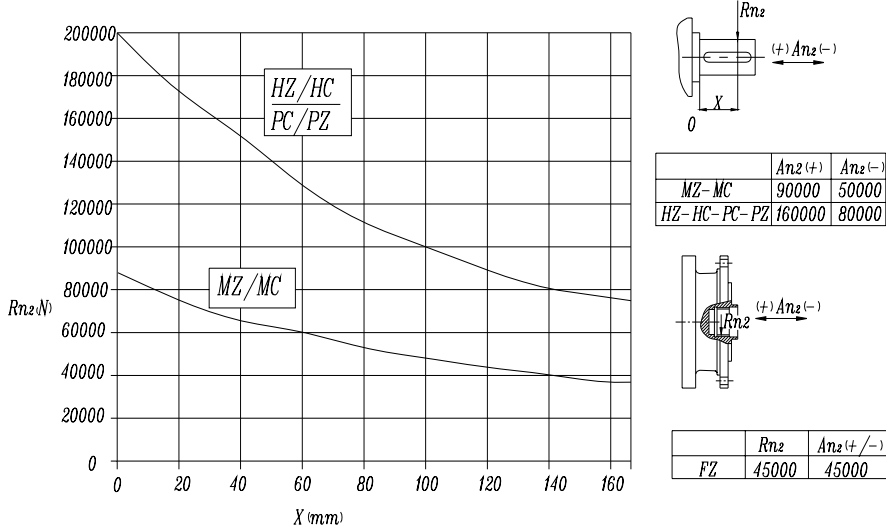

Load corrective factor fh2 on shafts	fh2= $n_2 \cdot h$		10 000	25 000	50 000	100 000	500 000	1 000 000
	fh2	MZ-MC-PC-PZ-FZ	1	0.74	0.58	0.46	0.27	0.21
		HZ-HC	1	0.76	0.61	0.50	0.31	0.25

Permissible radial loads on input shaft with Fh1 ($n_1 \cdot h=250\ 000$)

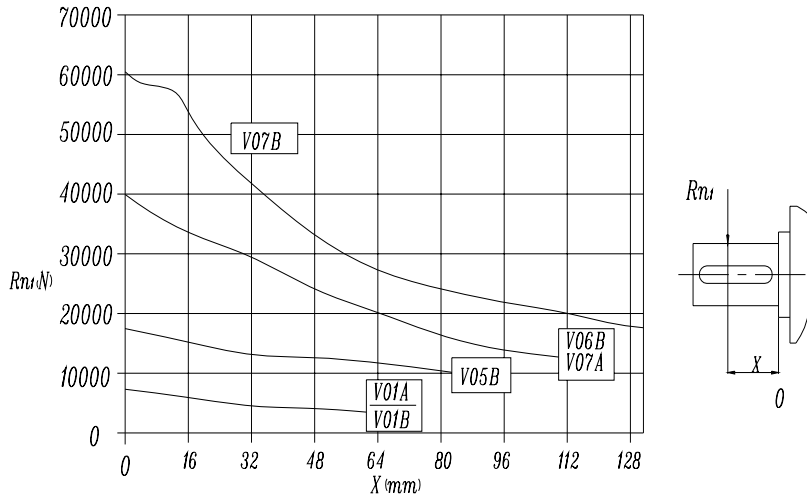

Load corrective factor fh1 on shafts	Fh1= $n_1 \cdot h$		250 000	500 000	1 000 000	2 00 000	5 000 000	10 000 000
	fh1		1	0.79	0.63	0.50	0.37	0.29

Planetary Gearbox

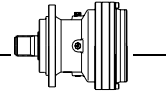

EP309L

M2'=18500N.m

I	I:	Mn ₂ (N.m)						P ₁ (KW)	P _t (KW) (t _a =20°C) (n ₁ =1500)	n ₁ (min ⁻¹)	n _{1max} (min ⁻¹)	M _b (N.m)	Brake type	
		n ₂ .h 10000	n ₂ .h 25000	n ₂ .h 50000	n ₂ .h 100000	n ₂ .h 500000	n ₂ .h 1000000							
L1	3.4	22 500	20 600	19 000	16 800	10 400	8 400	130	25	1 500	2 000	3 200	6L	
	4.4	22 500	20 600	19 000	16 800	10 400	8 400	130	25	1 500	2 000	3 200	6L	
	5.3	21 000	18 100	16 200	16 000	10 700	8 700	130	25	1 500	2 000	3 200	6L	
	6.2	17 000	14 400	13 000	13 000	10 400	8 500	130	25	1 500	2 000	3 200	6L	
L2	12.6	18 000	17 500	16 500	15 200	9 400	7 600	60	18	1 750	3 500	1 000	5K	
	16.1	21 300	20 600	19 000	15 600	9 600	7 800	60	18	1 750	3 500	1 000	5K	
	18.5	21 300	20 600	19 000	15 600	9 600	7 800	60	18	1 750	3 500	1 000	5K	
	22	18 000	17 500	16 500	15 200	9 400	7 600	60	18	1 750	3 500	1 000	5K	
	26.3	21 000	18 100	16 200	16 000	10 700	8 700	60	18	1 750	3 500	1000	5K	
	29.2	18 000	17 500	16 500	15 200	9 400	7 600	60	18	1 750	3 500	1000	5K	
	35.8	17 000	14 400	13 000	13 000	10 400	8 500	57	18	1 750	3 500	800	5E	
	42.5	17 000	14 400	13 000	13 000	10 400	8 500	42	18	1 750	3 500	500	5C	
	L3	42.5	18 000	17 500	16 500	15 200	9 400	7 600	42	11	1 750	3 500	440	4L
		54.6	21 300	20 600	19 000	15 600	9 600	7 800	36	11	1 750	3 500	440	4L
62.5		21 300	20 600	19 000	15 600	9 600	7 800	33	11	1 750	3 500	400	4K	
82.1		21 300	20 600	19 000	15 600	9 600	7 800	28	11	1 750	3 500	330	4H	
107		21 300	20 600	19 000	15 600	9 600	7 800	23	11	1 750	3 500	260	4F	
127		18 000	17 500	16 500	15 200	9 400	7 600	20	11	1 750	3 500	260	4F	
151		21 000	18 100	16 200	16 000	10 700	8 700	17	11	1 750	3 500	160	4D	
169		18 000	17 500	16 500	15 200	9 400	7 600	16	11	1 750	3 500	160	4D	
211		18 000	17 500	16 500	15 200	9 400	7 600	13	11	1 750	3 500	100	4B	
258		17 000	14 400	13 000	13 000	10 400	8 500	8	11	1 750	3 500	100	4B	
306	17 000	14 400	13 000	13 000	10 400	8 500	7	11	1 750	3 500	100	4B		
L4	278	21 300	20 600	19 000	15 600	9 600	7 800	10	7.5	1 750	3 500	100	4B	
	365	21 300	20 600	19 000	15 600	9 600	7 800	8	7.5	1 750	3 500	100	4B	
	474	21 300	20 600	19 000	15 600	9 600	7 800	6.5	7.5	1 750	3 500	50	4A	
	591	21 300	20 600	19 000	15 600	9 600	7 800	5.5	7.5	1 750	3 500	50	4A	
	768	21 300	20 600	19 000	15 600	9 600	7 800	4.5	7.5	1 750	3 500	50	4A	
	914	21 000	18 100	16 200	16 000	10 700	8 700	3.3	7.5	1 750	3 500	50	4A	
	1090	18 000	17 500	16 500	15 200	9 400	7 600	2.7	7.5	1 750	3 500	50	4A	
	1215	18 000	17 500	16 500	15 200	9 400	7 600	2.5	7.5	1 750	3 500	50	4A	
	1516	18 000	17 500	16 500	15 200	9 400	7 600	2.1	7.5	1 750	3 500	50	4A	
	1856	17 000	14 400	13 000	13 000	10 400	8 500	1.6	7.5	1 750	3 500	50	4A	
2202	17 000	14 400	13 000	13 000	10 400	8 500	1.4	7.5	1 750	3 500	50	4A		

$$M_{2max}=1.2 \times Mn2(n2 \times h=10\ 000)$$

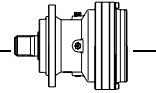

EP309R

M2'=18500N.m

	I 1:	Mn ₂ (N.m)						P ₁ (KW)	P _t (KW) (t _a =20°C) (n ₁ =1500)	n ₁ (min ⁻¹)	n _{1max} (min ⁻¹)	M _b (N.m)	Brake type
		n ₂ .h 10000	n ₂ .h 25000	n ₂ .h 50000	n ₂ .h 100000	n ₂ .h 500000	n ₂ .h 1000000						
R2	13	9 100	8 500	7 600	6 800	5 500	4 400	60	35	1 750	3 500	1000	5K
	16.7	11 000	9 800	8 900	12 500	7 900	6 400	50	35	1 750	3 500	1000	5K
	19.9	14 000	12 000	10 700	10 500	7 700	6 200	45	35	1 750	3 500	1000	5K
	23.6	16 000	14 000	12 500	11 200	8 000	6 500	45	35	1 750	3 500	800	5G
R3	32.2	12 000	11 000	9 500	7 200	4 400	3 600	25	20	1 750	3 500	440	4L
	41.3	14 300	12 600	10 000	8 600	5 600	4 800	22	20	1 750	3 500	440	4L
	47.4	17 300	14 600	11 000	9 600	5 600	4 800	20	20	1 750	3 500	440	4L
	56.4	18 000	17 000	16 000	14 200	8 400	6 600	20	20	1 750	3 500	400	4K
	67.3	21 000	18 100	16 200	16 000	10 700	8 700	22	20	1 750	3 500	400	4K
	75	18 000	17 500	16 500	15 200	9 400	7 600	20	20	1 750	3 500	330	4H
	91.7	17 000	14 400	13 000	13 000	10 400	8 500	18	20	1 750	3 500	260	4F
	109	17 000	14 400	13 000	13 000	10 400	8 500	16	20	1 750	3 500	260	4F
R4	128	21 300	20 600	19 000	15 600	9 600	7 800	15.5	14	1 750	3 500	260	4F
	168	21 300	20 600	19 000	15 600	9 600	7 800	15	14	1 750	3 500	160	4D
	219	21 300	20 600	19 000	15 600	9 600	7 800	12	14	1 750	3 500	160	4D
	260	18 000	17 500	16 500	15 200	9 400	7 600	10.5	14	1 750	3 500	100	4B
	310	21 000	18 100	16 200	16 000	10 700	8 700	9	14	1 750	3 500	100	4B
	346	18 000	17 500	16 500	15 200	9 400	7 600	8	14	1 750	3 500	100	4B
	433	18 000	17 500	16 500	15 200	9 400	7 600	7	14	1 750	3 500	50	4A
	529	17 000	14 400	13 000	13 000	10 400	8 500	4.5	14	1 750	3 500	50	4A
	627	17 000	14 400	13 000	13 000	10 400	8 500	4	14	1 750	3 500	50	4A
	714	7 000	5 900	5 500	5 500	4 700	3 850	1.5	12	1 750	3 500	50	4A

$$M_{2max}=1.2 \times Mn_2(n_2 \times h=10\ 000)$$

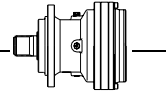

EP309L

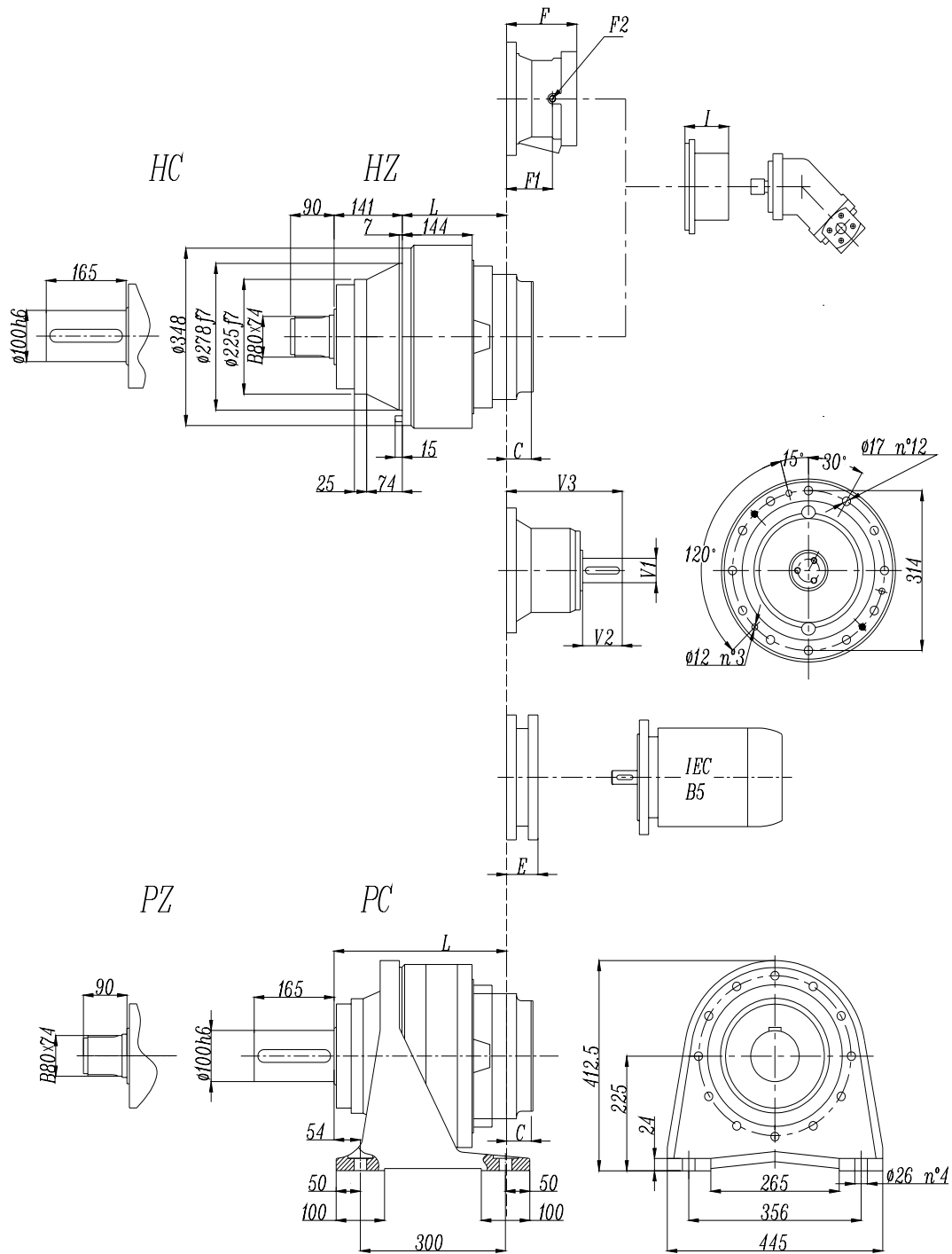

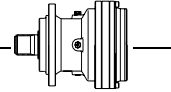

EP309L

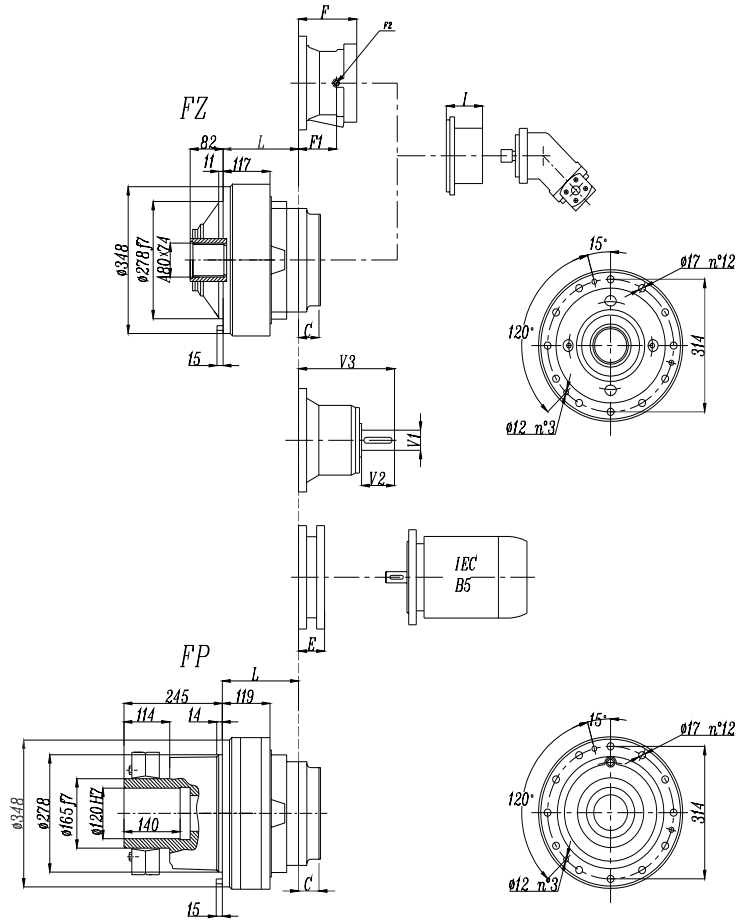

FP version

Max. transmissible

25000 N.m

	L				Ref. weight (without input) (Kg)				C	I	Brake				
	HZ HC	PC PZ	FZ	FP	HZ HC	PC PZ	FZ	FP			F	F1	F2	Type	Ref. Weight
309L1	126	267	99	101	115	130	95	100	51	According to hydraulic motor	201	153	1/4 G	6	38 Kg
309L2	219	360	192	194	127	142	107	112	37		145	95	1/4 G	5	22 Kg
309L3	284	425	257	259	134	149	114	119	37		105	65	1/4 G	4	15 Kg
309L4	337	478	310	312	138	153	118	123	37		105	65	1/4 G	4	15 Kg

	E (IEC motor input)												
	IEC 71	IEC 80	IEC 90	IEC 100	IEC 112	IEC 132	IEC 160	IEC 180	IEC 200	IEC 225	IEC 250		
309L1								195	186	216	216		
309L2						114	144	144	174				
309L3	65	84	84	94	94	114	144						
309L4	65	84	84	94	94	114	144						

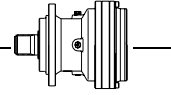

EP309R

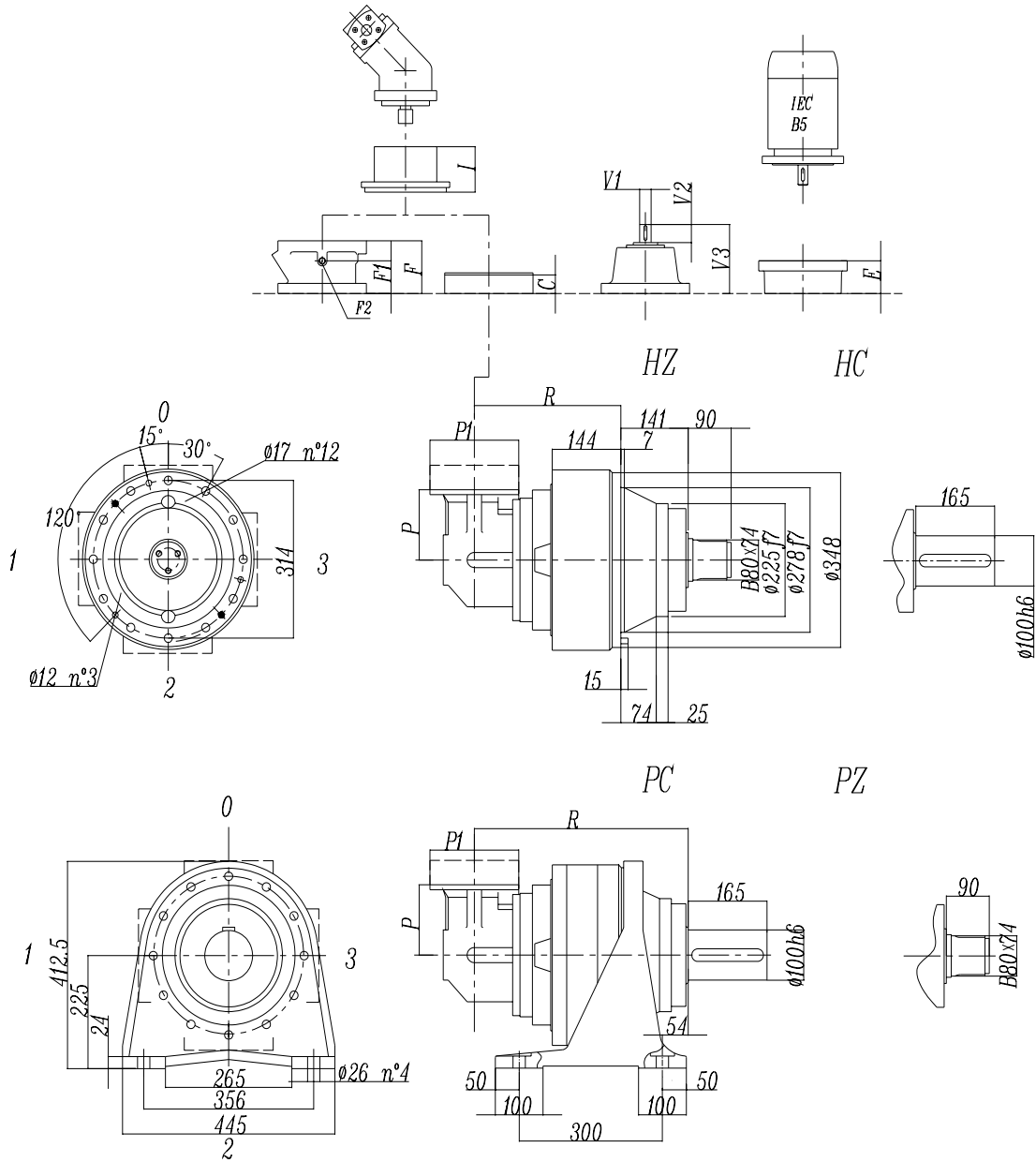

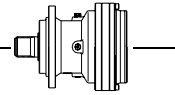

EP309R

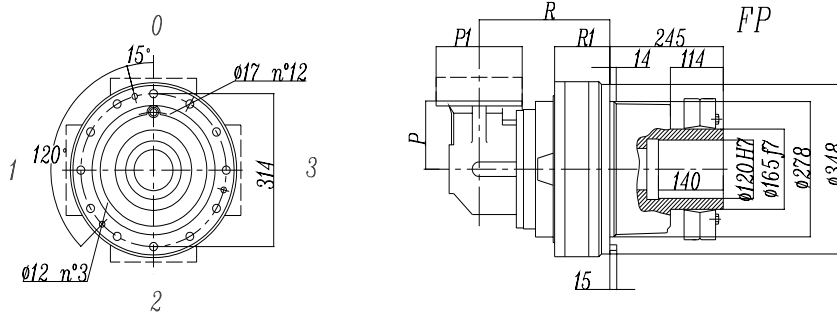
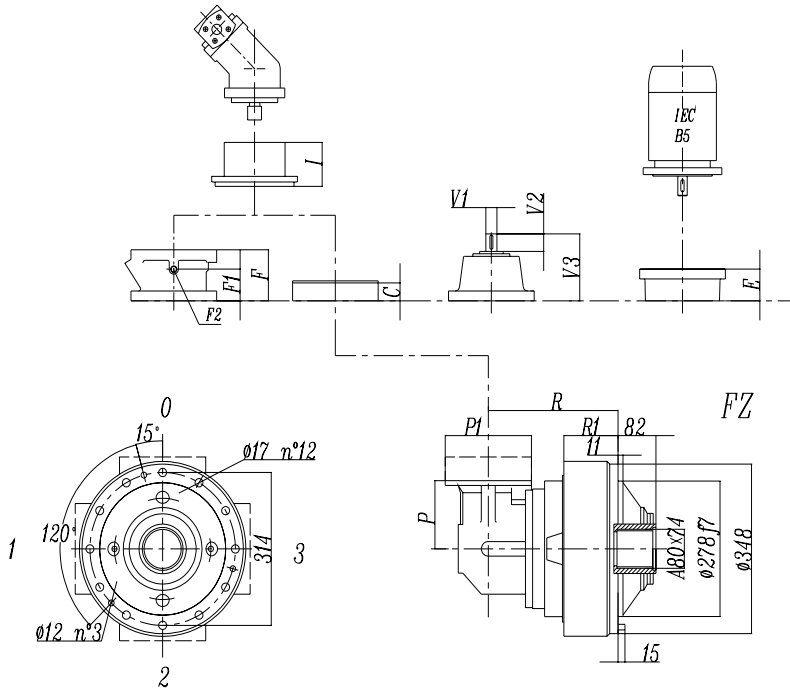

FP version
Max. transmissible
25000 N.m

	R				Ref. weight (without input) (Kg)				C	P	I	Brake				
	HZ HC	PC PZ	FZ	FP	HZ HC	PC PZ	FZ	FP				F	F1	F2	Type	Ref. Weight 15 Kg
309R2	245	386	218	220	165	180	145	150	37	225	According to hydraulic motor	145	95	1/4 G	4	22
309R3	311	452	284	286	147	162	127	132	37	140		105	65	1/4 G	4	15
309R4	376	517	349	351	148	163	128	133	37	122		105	65	1/4 G	4	15

	P1	R1				E (IEC motor input)									
		HZ	HC	FZ	FP	IEC 71	IEC 80	IEC 90	IEC 100	IEC 112	IEC 132	IEC 160	IEC 180	IEC 200	
309R2	245	168	168	141	143						114	144	144	174	
309R3	186	144	144	117	119	65	84	84	94	94	114	144			
309R4	186	144	144	117	119	65	84	84	94	94	114	144			

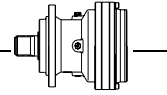

EP309L - EP309R

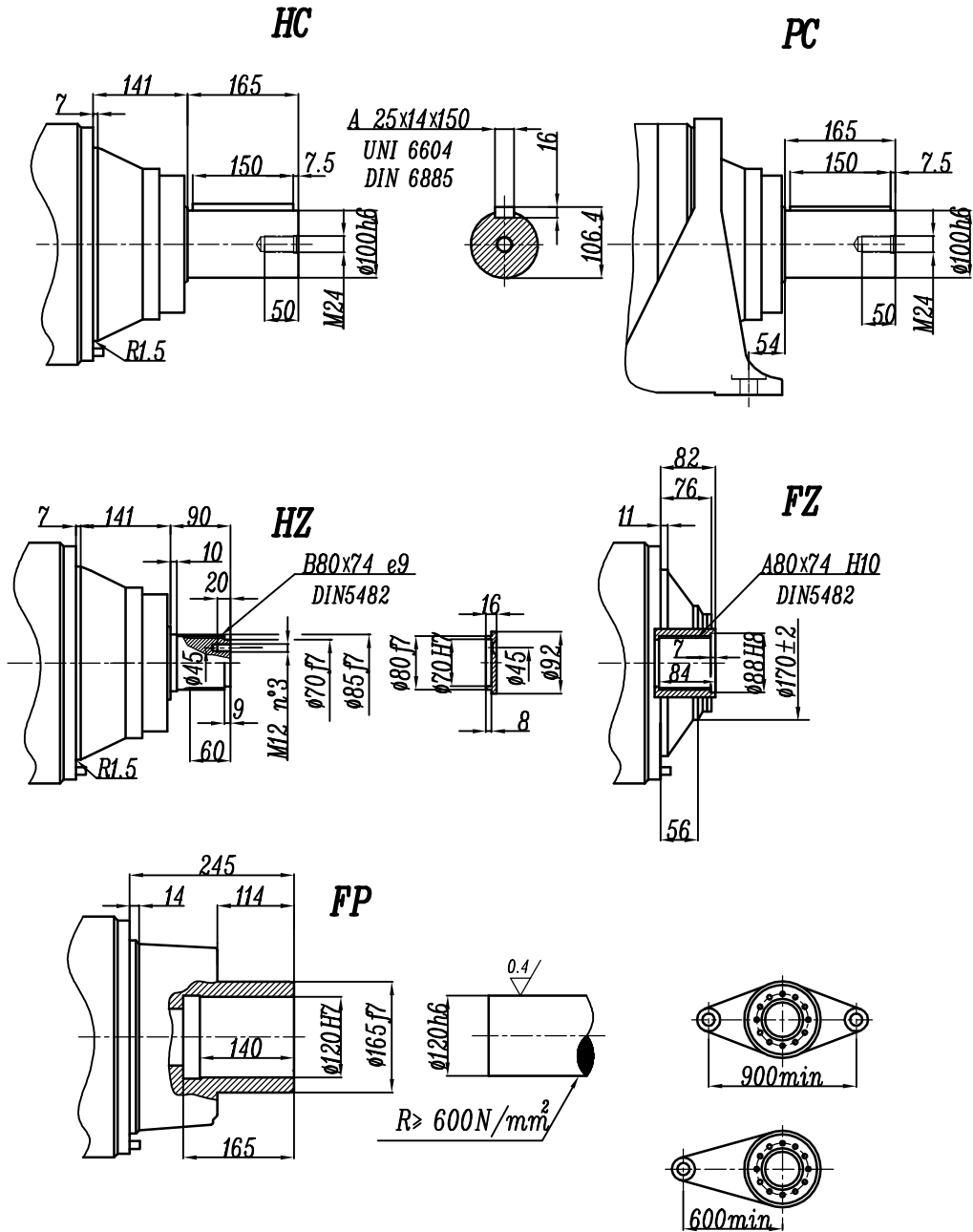

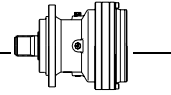

EP309L - EP309R

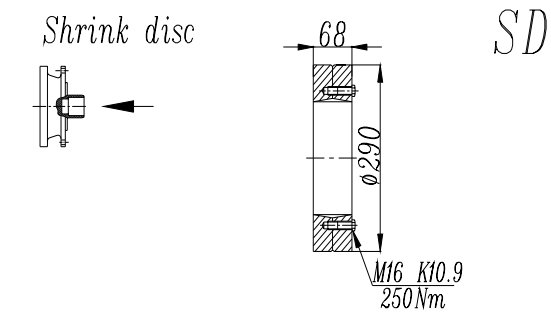
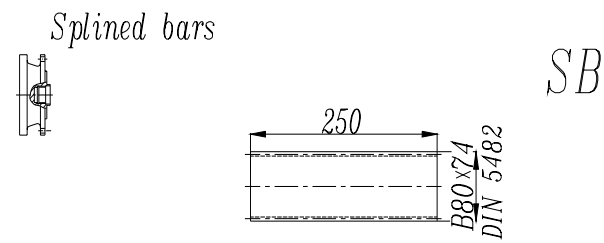
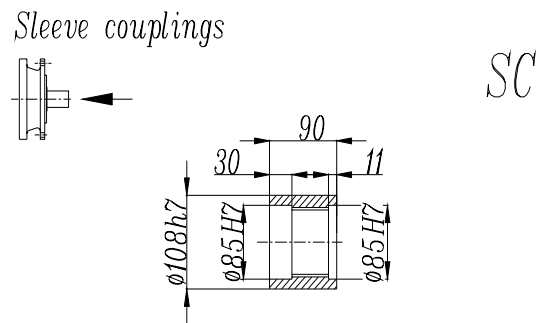
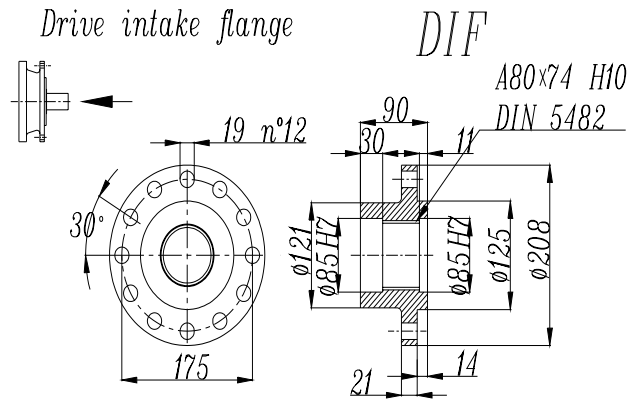

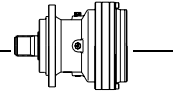

EP309L - EP309R

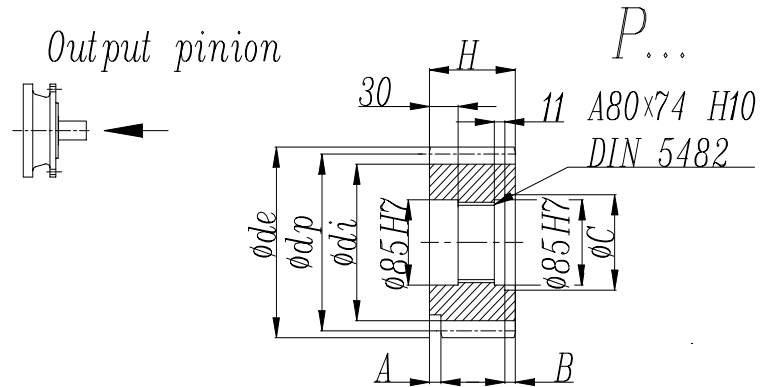

	m	z	x	dp	di	de	H	A	B	C
PFG	8	16	0.5000	128	117	149.5	90	0	0	0
PHC	10	12	0.4500	120	104	145	90	0	0	0
PHE	10	14	0.320	140	121	162.5	116	13	26	95
PHF	10	15	0.150	150	130	171.5	107	20	17	100
PHG	10	16	0.500	160	145	186	90	10	0	0
PHH1	10	17	0	170	145	190	90	0	0	0
PHH2	10	17	0.500	170	154	198	90	0	0	0
PLD	12	13	0.500	156	138	192	102	0	12	95
PLE	12	14	0.500	168	150	199.2	90	0	0	0
PLI	12	18	0.500	216	198	249.6	107	7	17	95
PLT	12	26	0	312	282	336	90	0	0	0

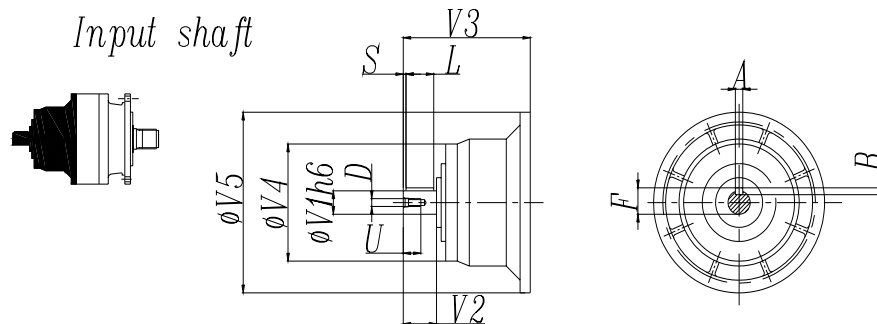

	CODE	V1	V2	V3	V4	V5	A	B	F	L	S	D	U
309L1	V07B	80	130	315	200	345	22	14	85	110	10	M16	36
	V07A	60	105	313	155	345	18	11	64	90	7.5	M16	36
309L2	V05B	48	82	239	155	245	14	9	51.5	70	6	M16	36
309L3	V01A	24	36	137.5	120	186	8	7	27	30	3	M8	19
	V01B	38	58	158	120	186	10	8	41	50	4	M12	28
309L4	V01A	24	36	137.5	120	186	8	7	27	30	3	M8	19
	V01B	38	58	158	120	186	10	8	41	50	4	M12	28
309R2	V05B	48	82	239	155	245	14	9	51.5	70	6	M16	36
309 R3-R4	V01A	24	36	137.5	120	186	8	7	27	30	3	M8	19
	V01B	38	58	158	120	186	10	8	41	50	4	M12	28

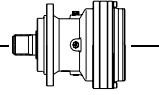

EP309L - EP309R

Permissible radial and axial loads on output shaft with Fh2 ($n_2 \cdot h=10\ 000$)

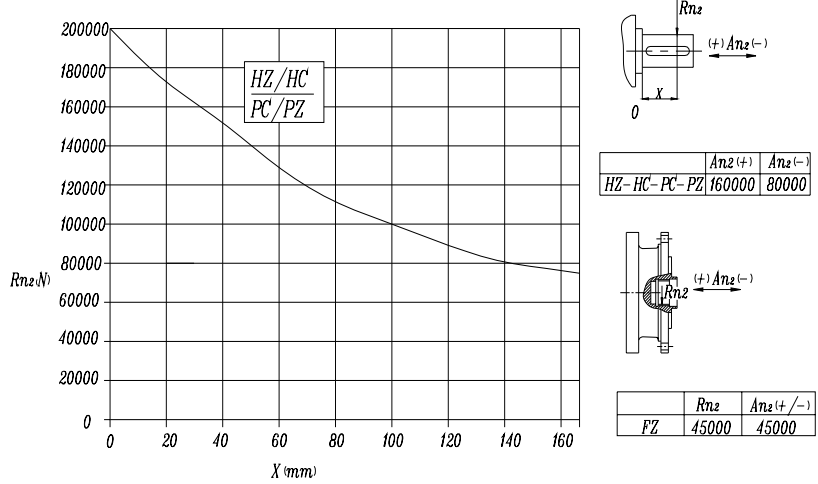

Load corrective factor fh2 on shafts	fh2= n2 • h		10 000	25 000	50 000	100 000	500 000	1 000 000
	fh2	MZ-MC-PC-PZ-FZ	HZ-HC	1	0.74	0.58	0.46	0.27
			1	0.76	0.61	0.50	0.31	0.25

Permissible radial loads on input shaft with Fh1 ($n_1 \cdot h=250\ 000$)

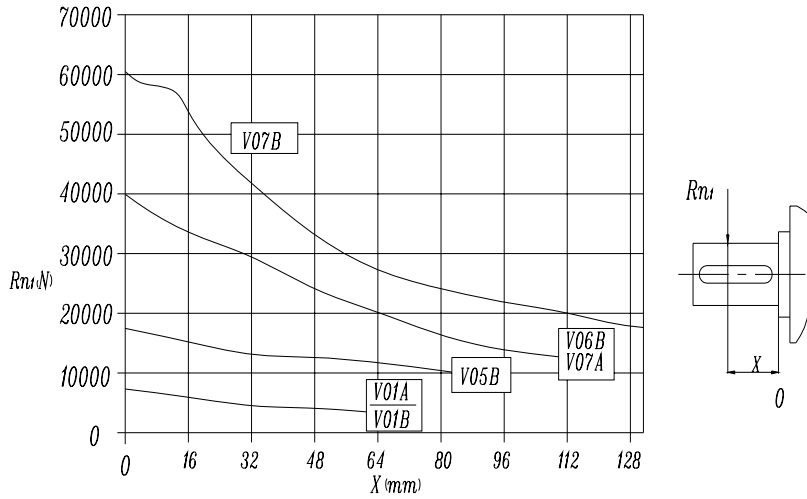

Load corrective factor fh1 on shafts	Fh1= n1 • h		250 000	500 000	1 000 000	2 00 000	5 000 000	10 000 000
	fh1			1	0.79	0.63	0.50	0.37

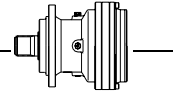

EP310L

M2³=25000N.m

	I 1:	Mn ₂ (N.m)						P ₁ (KW)	P _t (KW) (t _a =20°C) (n ₁ =1500)	n ₁ (min ⁻¹)	n _{1max} (min ⁻¹)	M _b (N.m)	Brake type
		n ₂ .h 10000	n ₂ .h 25000	n ₂ .h 50000	n ₂ .h 100000	n ₂ .h 500000	n ₂ .h 1000000						
L1	4.2	30000	30000	26000	21000	13000	11000	150	35	1000	1500		
	5.0	29000	25000	22000	20000	13000	11000	150	35	1000	1500		
	6.8	26000	21000	18000	17000	12000	10000	150	35	1000	1500		
L2	15.5	30000	30000	26000	21000	13000	11000	100	22	1500	2500	2100	6G
	17.6	30000	30000	26000	21000	13000	11000	90	22	1500	2500	2100	6G
	21.0	29000	25000	22000	20000	13000	11000	80	22	1500	2500	1500	6E
	24.7	29000	25000	22000	20000	13000	11000	75	22	1500	2500	1500	6E
	28.9	29000	25000	22000	20000	13000	11000	70	22	1500	2500	1100	6C
	33.7	26000	21000	18000	17000	12000	10000	65	22	1500	2500	1100	6C
	39.4	26000	21000	18000	17000	12000	10000	55	22	1500	2500	850	6B
	48.3	26000	21000	18000	17000	12000	10000	50	22	1500	2500	850	6B
	L3	56.7	30000	30000	26000	21000	13000	11000	50	18	1 750	3 500	630
73.9		30000	30000	26000	21000	13000	11000	42	18	1 750	3 500	630	5E
88.0		30000	30000	26000	21000	13000	11000	37	18	1 750	3 500	500	5C
105		29000	25000	22000	20000	13000	11000	32	18	1 750	3 500	400	5B
124		29000	25000	22000	20000	13000	11000	28	18	1 750	3 500	400	5B
145		29000	25000	22000	20000	13000	11000	24	18	1 750	3 500	400	5B
161		29000	25000	22000	20000	13000	11000	22	18	1 750	3 500	400	5B
197		29000	25000	22000	20000	13000	11000	19	18	1 750	3 500	400	5B
220		26000	21000	18000	17000	12000	10000	14	18	1 750	3 500	400	5B
269		26000	21000	18000	17000	12000	10000	11.5	18	1 750	3 500	400	5B
330		26000	21000	18000	17000	12000	10000	9.5	18	1 750	3 500	400	5B
L4	329	30000	30000	26000	21000	13000	11000	12	11	1 750	3 500	100	4B
	426	30000	30000	26000	21000	13000	11000	9.5	11	1 750	3 500	100	4B
	508	30000	30000	26000	21000	13000	11000	8.5	11	1 750	3 500	100	4B
	604	29000	25000	22000	20000	13000	11000	6.5	11	1 750	3 500	100	4B
	713	29000	25000	22000	20000	13000	11000	5.6	11	1 750	3 500	50	4A
	834	29000	25000	22000	20000	13000	11000	4.8	11	1 750	3 500	50	4A
	930	29000	25000	22000	20000	13000	11000	4.4	11	1 750	3 500	50	4A
	1160	29000	25000	22000	20000	13000	11000	3.8	11	1 750	3 500	50	4A
	1268	26000	21000	18000	17000	12000	10000	3	11	1 750	3 500	50	4A
	1420	29000	25000	22000	20000	13000	11000	3.3	11	1 750	3 500	50	4A
	1582	26000	21000	18000	17000	12000	10000	2.5	11	1 750	3 500	50	4A
	1937	26000	21000	18000	17000	12000	10000	2.2	11	1 750	3 500	50	4A
	2373	26000	21000	18000	17000	12000	10000	1.8	11	1 750	3 500	50	4A

$$M_{2max}=1.2 \times Mn_2(n_2 \times h=10\ 000)$$

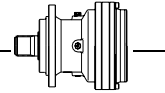

EP310R

M₂'=25000N.m

	I 1:	Mn ₂ (N.m)						P ₁ (KW)	P _t (KW) (t _a =20°C) (n ₁ =1500)	n ₁ (min ⁻¹)	n _{1max} (min ⁻¹)	M _b (N.m)	Brake type	
		n _{2,h} 10000	n _{2,h} 25000	n _{2,h} 50000	n _{2,h} 100000	n _{2,h} 500000	n _{2,h} 1000000							
R2	12.3	21000	20000	19000	16000	10000	8000	130	55	1 500	2 500	2600	6K	
	14.6	25000	21500	20000	17500	11000	8500	130	55	1 500	2 500	2100	6G	
	20.0	26000	21000	18000	17000	12000	10000	130	55	1 500	2 500	1500	6E	
R3	39.6	21000	20000	19000	16000	10000	8000	45	20	1 750	3 500	440	4L	
	45.1	26000	21000	18000	17000	12000	10000	45	20	1 750	3 500	440	4L	
	53.7	29000	25000	22000	20000	13000	11000	41	20	1 750	3 500	440	4L	
	63.3	29000	25000	22000	20000	13000	11000	37	20	1 750	3 500	440	4L	
	74.1	29000	25000	22000	20000	13000	11000	33	20	1 750	3 500	440	4L	
	86.3	26000	21000	18000	17000	12000	10000	27	20	1 750	3 500	400	4K	
	101	26000	21000	18000	17000	12000	10000	24	20	1 750	3 500	400	4K	
	124	26000	21000	18000	17000	12000	10000	20	20	1 750	3 500	330	4H	
	R4	145	30000	30000	26000	21000	13000	11000	21	14	1 750	3 500	330	4H
		189	30000	30000	26000	21000	13000	11000	17	14	1 750	3 500	330	4H
226		30000	30000	26000	21000	13000	11000	15	14	1 750	3 500	260	4F	
268		29000	25000	22000	20000	13000	11000	13	14	1 750	3 500	160	4D	
317		29000	25000	22000	20000	13000	11000	11.5	14	1 750	3 500	160	4D	
371		29000	25000	22000	20000	13000	11000	10.2	14	1 750	3 500	100	4B	
413		29000	25000	22000	20000	13000	11000	9.3	14	1 750	3 500	100	4B	
505		29000	25000	22000	20000	13000	11000	7.7	14	1 750	3 500	100	4B	
563		26000	21000	18000	17000	12000	10000	6	14	1 750	3 500	100	4B	
689		26000	21000	18000	17000	12000	10000	5	14	1 750	3 500	50	4A	
845	26000	21000	18000	17000	12000	10000	4.3	14	1 750	3 500	50	4A		

$$M_{2max}=1.2 \times Mn_2(n_2 \times h=10\ 000)$$

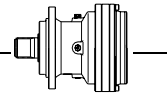

EP310L

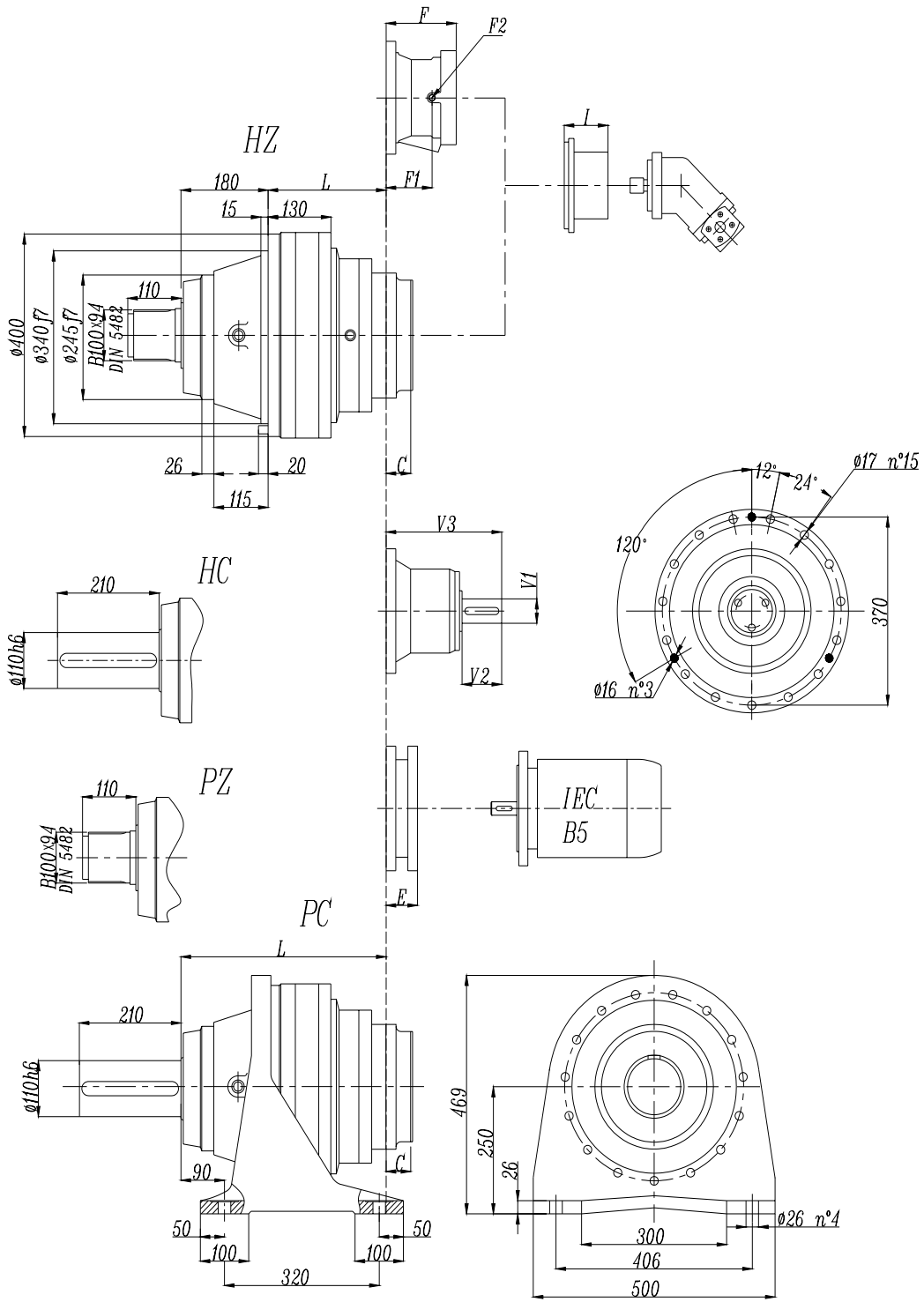

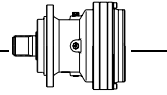

EP310L

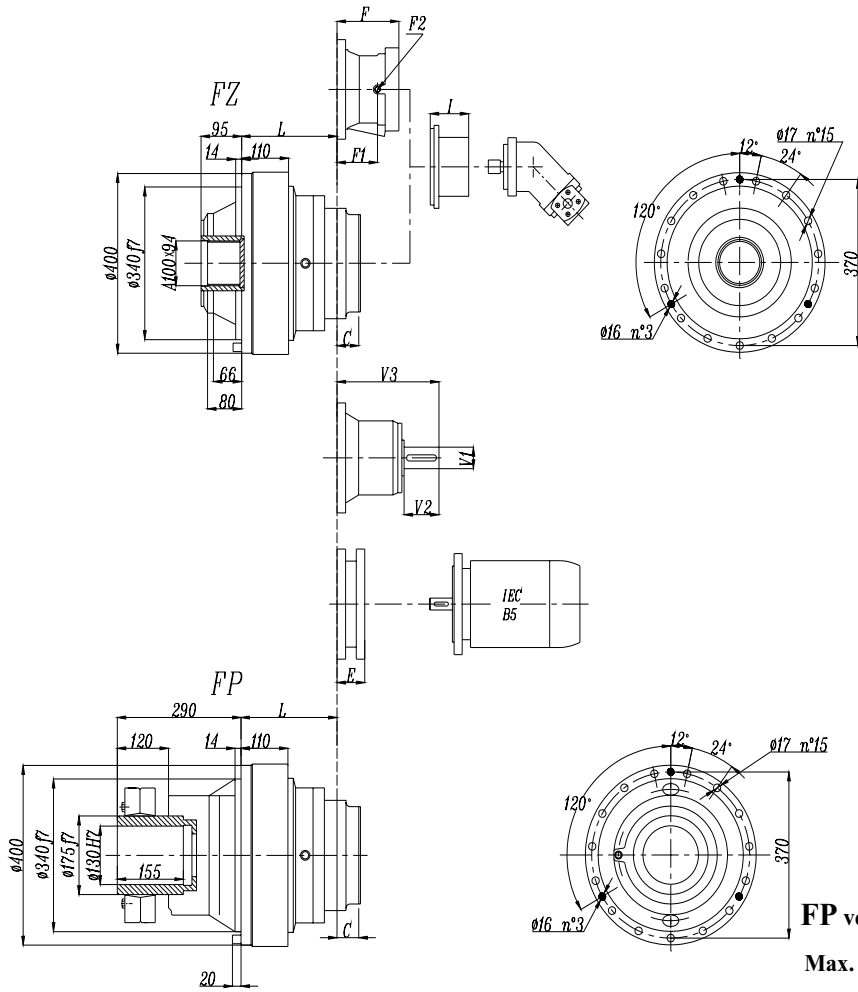

FP version

Max. transmissible

36000 N.m

	L				Ref. weight (without input) (Kg)				C	I	Brake				
	HZ HC	PC PZ	FZ	FP	HZ HC	PC PZ	FZ	FP			F	F1	F2	Type	Ref. Weight
310L1	108	288	88	88	135	130	110	115	88	According to hydraulic motor					
310L2	244	424	224	224	165	142	140	145	45		195	147	1/4 G	6	38 Kg
310L3	313	493	293	293	178	149	153	158	37		145	95	1/4 G	5	22 Kg
310L4	366	546	346	346	182	153	157	162	37		105	65	1/4 G	4	15 Kg

	E (IEC motor input)												
	IEC 71	IEC 80	IEC 90	IEC 100	IEC 112	IEC 132	IEC 160	IEC 180	IEC 200	IEC 225	IEC 250		
310L1									271	301	281		
310L2								152	182	212	193		
310L3						114	144	144	174				
310L4	65	84	84	94	94	114	144						

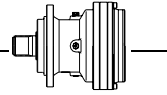

EP310R

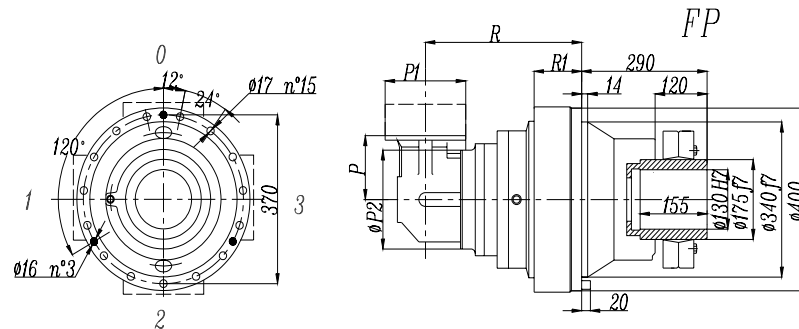
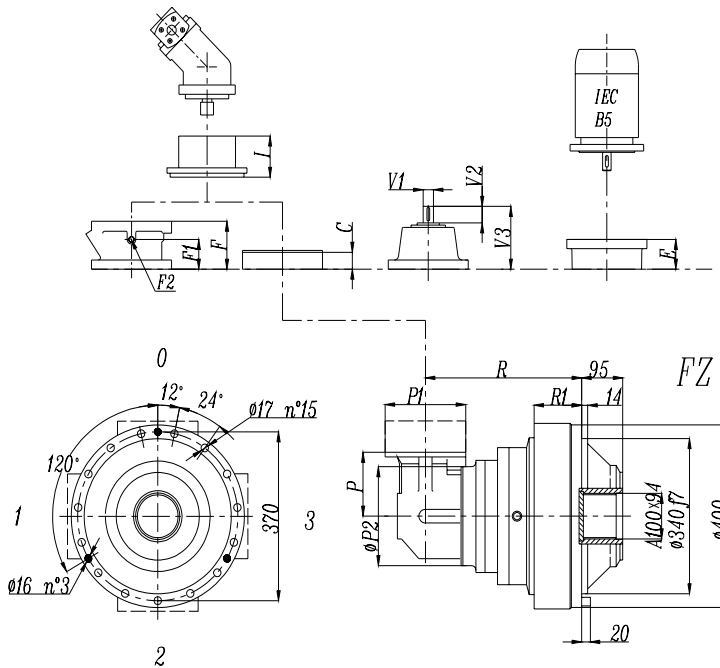

FP version
Max. transmissible
36000 N.m

	R				Ref. weight (without input) (Kg)				C	P	I	Brake				
	HZ HC	PC PZ	FZ	FP	HZ HC	PC PZ	FZ	FP				F	F1	F2	Type	Ref. Weight 15 Kg
310R2	315	495	218	295	260	280	240	250	45	345	According to hydraulic motor	195	147	1/4 G	6	38
310R3	381	561	284	361	189	209	164	169	37	140		145	95	1/4 G	4	22
310R4	405	585	349	385	194	214	169	174	37	140		105	65	1/4 G	4	15

	P1	R1				E (IEC motor input)									
		HZ	HC	FZ	FP	IEC 71	IEC 80	IEC 90	IEC 100	IEC 112	IEC 132	IEC 160	IEC 180	IEC 200	IEC 225
310R2	292	130	130	110	110								152	182	212
310R3	186	130	130	110	110						114	144	144	174	174
310R4	186	130	130	110	110	65	84	84	94	94	114	144			

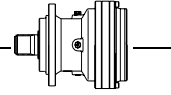

EP310L - EP310R

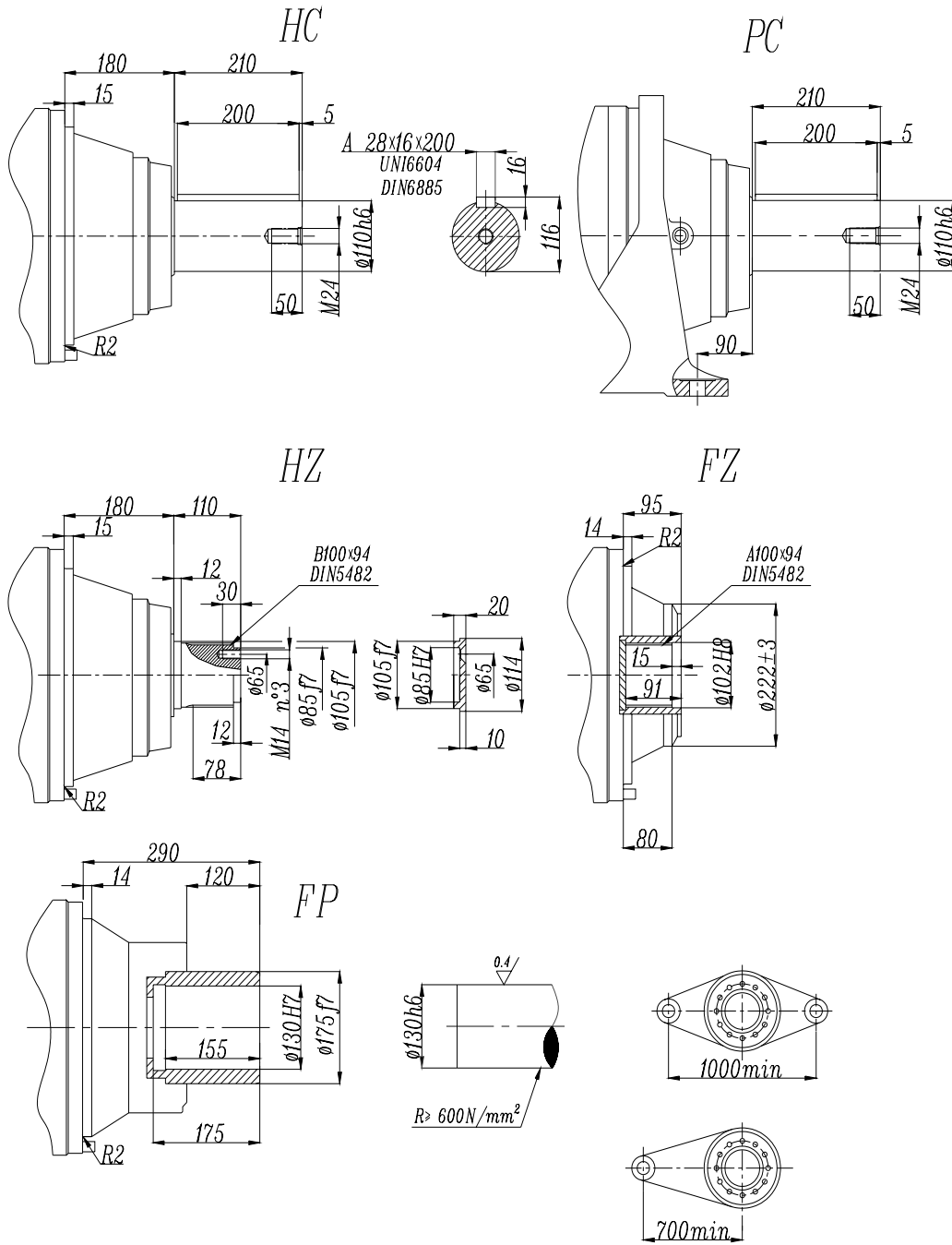

FP version

Max. transmissible

36000 N.m

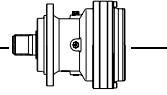

EP310L - EP310R

Drive intake flange

DIF

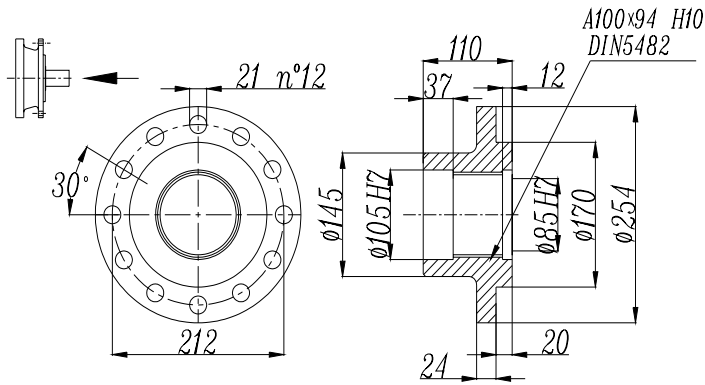

Sleeve couplings

SC

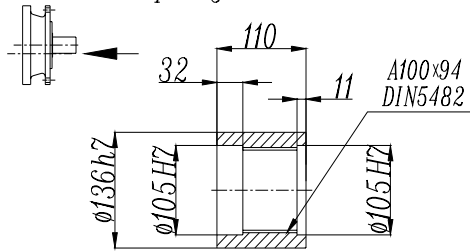

Splined bars

SB

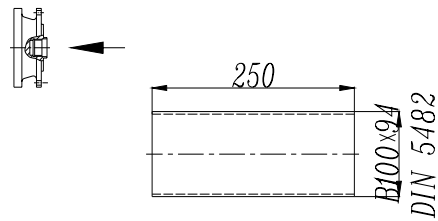

Shrink disc

SD

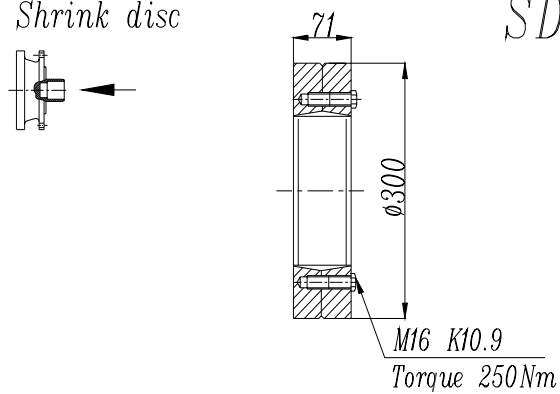

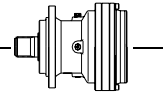

EP310L - EP310R

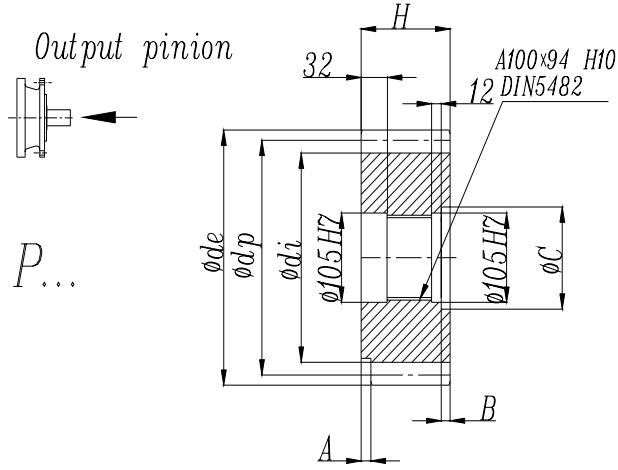

	m	z	x	dp	di	de	H	A	B	C
PLQ	12	23	0	276	246	300	110	0	0	0
PPD	16	13	0.5000	208	184	252.5	145	0	35	116
PPF	16	15	0.450	240	215	280	125	0	15	120

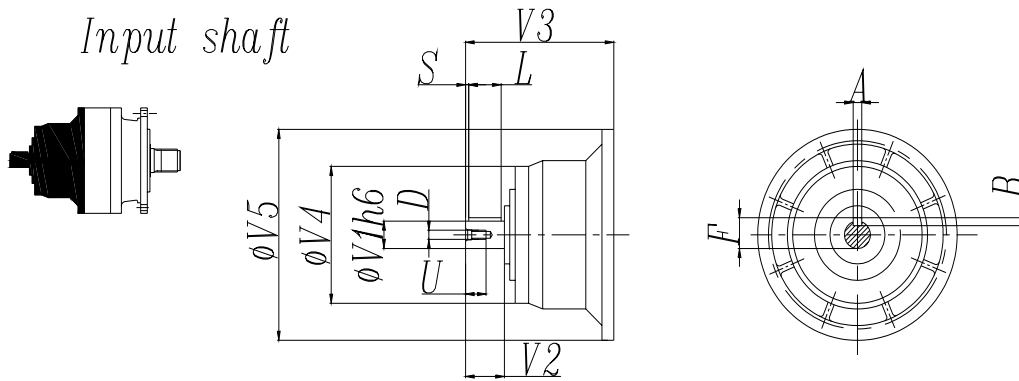

	CODE	V1	V2	V3	V4	V5	A	B	F	L	S	D	U
310L1	V10B	80	130	377	200	400	22	14	85	110	10	M16	36
310L2	V06B	60	105	307	155	292	18	11	64	90	7.5	M16	36
310L3	V05B	48	82	239	155	245	14	9	51.5	70	6	M16	36
310L4	V01A	24	36	137.5	120	186	8	7	27	30	3	M8	19
	V01B	38	58	158	120	186	10	8	41	50	4	M12	28
310R2	V06B	60	105	307	155	292	18	11	64	90	7.5	M16	36
310 R3-R4	V01A	24	36	137.5	120	186	8	7	27	30	3	M8	19
	V01B	38	58	158	120	186	10	8	41	50	4	M12	28

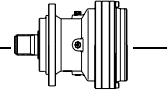

EP310L - EP310R

Permissible radial and axial loads on output shaft with Fh2 ($n_2 \cdot h=10\ 000$)

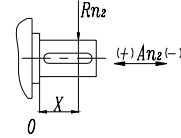
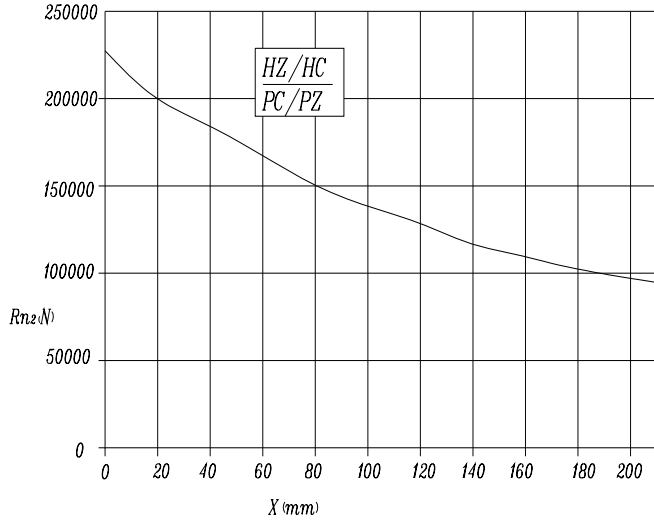

	$An_2 (+)$	$An_2 (-)$
HZ-HC-PC-PZ	170000	100000

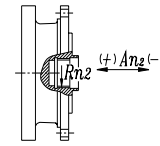

	Rn_2	$An_2 (+/-)$
FZ	65000	52000

Load corrective factor fh2 on shafts	$fh_2 = n_2 \cdot h$		10 000	25 000	50 000	100 000	500 000	1 000 000
	fh2	MZ-MC-PC-PZ-FZ	1	0.74	0.58	0.46	0.27	0.21
		HZ-HC	1	0.76	0.61	0.50	0.31	0.25

Permissible radial loads on input shaft with Fh1 ($n_1 \cdot h=250\ 000$)

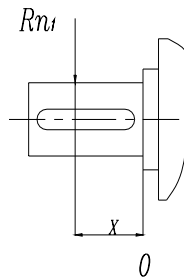
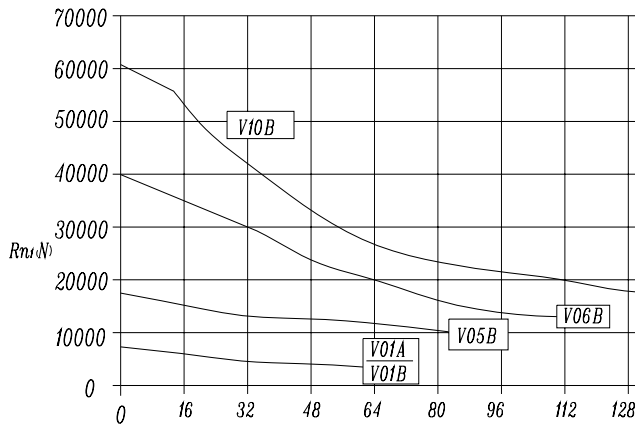

Load corrective factor fh1 on shafts	$Fh_1 = n_1 \cdot h$		250 000	500 000	1 000 000	2 00 000	5 000 000	10 000 000
	fh1	1	0.79	0.63	0.50	0.37	0.29	

Planetary Gearbox

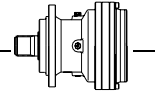

EP311L

M2'=35000N.m

I	I:	Mn ₂ (N.m)						P ₁ (KW)	P _t (KW) (t _a =20°C) (n ₁ =1500)	n ₁ (min ⁻¹)	n _{1max} (min ⁻¹)	M _b (N.m)	Brake type
		n ₂ .h 10000	n ₂ .h 25000	n ₂ .h 50000	n ₂ .h 100000	n ₂ .h 500000	n ₂ .h 1000000						
L1	4.1	45000	45000	37400	32000	19700	16000	180	35	750	1000		
	5.3	43000	36500	32300	32000	19700	16000	180	35	750	1000		
	6.2	34000	29500	27000	27000	18600	15100	180	35	750	1000		
L2	14.0	45000	45000	37400	32000	19700	16000	100	25	1500	2500	3200	6L
	18.0	45000	45000	37400	32000	19700	16000	100	25	1500	2500	3200	6L
	23.1	43000	36500	32300	32000	19700	16000	100	25	1500	2500	2600	6K
	27.6	43000	36500	32300	32000	19700	16000	100	25	1500	2500	2100	6G
	32.7	43000	36500	32300	32000	19700	16000	90	25	1500	2500	2100	6G
	38.8	34000	29500	27000	27000	18600	15100	80	25	1500	2500	1500	6E
	51.4	45000	45000	37400	32000	19700	16000	60	18	1 750	3 500	1000	5K
L3	66.0	45000	45000	37400	32000	19700	16000	50	18	1 750	3 500	1000	5K
	75.6	45000	45000	37400	32000	19700	16000	46	18	1 750	3 500	800	5G
	84.7	43000	36500	32300	32000	19700	16000	42	18	1 750	3 500	630	5E
	97.0	43000	36500	32300	32000	19700	16000	38	18	1 750	3 500	630	5E
	116	43000	36500	32300	32000	19700	16000	35	18	1 750	3 500	500	5C
	138	43000	36500	32300	32000	19700	16000	30	18	1 750	3 500	500	5C
	154	43000	36500	32300	32000	19700	16000	28	18	1 750	3 500	400	5B
	188	43000	36500	32300	32000	19700	16000	25	18	1 750	3 500	400	5B
	223	43000	36500	32300	32000	19700	16000	22	18	1 750	3 500	400	5B
	265	34000	29500	27000	27000	18600	15100	16	18	1 750	3 500	400	5B
L4	256	45000	45000	37400	32000	19700	16000	23	11	1 750	3 500	260	4F
	287	43000	36500	32300	32000	19700	16000	21	11	1 750	3 500	260	4F
	336	45000	45000	37400	32000	19700	16000	18	11	1 750	3 500	260	4F
	436	45000	45000	37400	32000	19700	16000	14	11	1 750	3 500	160	4D
	560	43000	36500	32300	32000	19700	16000	11.2	11	1 750	3 500	160	4D
	666	43000	36500	32300	32000	19700	16000	9.5	11	1 750	3 500	100	4B
	795	43000	36500	32300	32000	19700	16000	8	11	1 750	3 500	100	4B
	886	43000	36500	32300	32000	19700	16000	7.3	11	1 750	3 500	100	4B
	1106	43000	36500	32300	32000	19700	16000	6	11	1 750	3 500	100	4B
	1353	43000	36500	32300	32000	19700	16000	5	11	1 750	3 500	50	4A
1606	43000	36500	32300	32000	19700	16000	4.3	11	1 750	3 500	50	4A	
1906	34000	29500	27000	27000	18600	15100	3.1	11	1 750	3 500	50	4A	

$$M_{2max}=1.2 \times Mn_2(n_2 \times h=10\ 000)$$

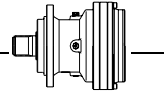

EP311R

M2'=35000N.m

	I 1:	Mn ₂ (N.m)						P ₁ (KW)	P _t (KW) (t _a =20°C) (n ₁ =1500)	n ₁ (min ⁻¹)	n _{1max} (min ⁻¹)	M _b (N.m)	Brake type
		n _{2,h} 10000	n _{2,h} 25000	n _{2,h} 50000	n _{2,h} 100000	n _{2,h} 500000	n _{2,h} 1000000						
R2	12.0	28000	27000	25000	24000	16000	12500	150	75	1 500	2 500	3200	6L
	15.4	35000	33000	31000	30000	18000	15000	150	75	1 500	2 500	3200	6L
	18.2	34000	30000	27000	26000	18000	15000	150	75	1 500	2 500	2600	6K
R3	53.1	34000	29500	27000	27000	18600	15100	60	40	1 750	3 500	800	5G
	68.1	45000	45000	37400	32000	19700	16000	50	40	1 750	3 500	800	5G
	87.5	43000	36500	32300	32000	19700	16000	45	40	1 750	3 500	630	5E
	104	43000	36500	32300	32000	19700	16000	40	40	1 750	3 500	630	5E
	124	43000	36500	32300	32000	19700	16000	35	40	1 750	3 500	500	5C
	147	34000	29500	27000	27000	18600	15100	30	40	1 750	3 500	400	5B
R4	155	45000	45000	37400	32000	19700	16000	32	22	1 750	3 500	400	4K
	174	43000	36500	32300	32000	19700	16000	29	22	1 750	3 500	330	4H
	199	43000	36500	32300	32000	19700	16000	26	22	1 750	3 500	330	4H
	237	43000	36500	32300	32000	19700	16000	23	22	1 750	3 500	260	4F
	283	43000	36500	32300	32000	19700	16000	20.5	22	1 750	3 500	260	4F
	315	43000	36500	32300	32000	19700	16000	18.6	22	1 750	3 500	160	4D
	385	43000	36500	32300	32000	19700	16000	15.5	22	1 750	3 500	160	4D
	457	43000	36500	32300	32000	19700	16000	13.3	22	1 750	3 500	160	4D
	543	34000	29500	27000	27000	18600	15100	9.5	22	1 750	3 500	100	4B

$$M_{2max}=1.2 \times Mn_2(n_2 \times h=10\ 000)$$

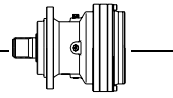

EP311 L

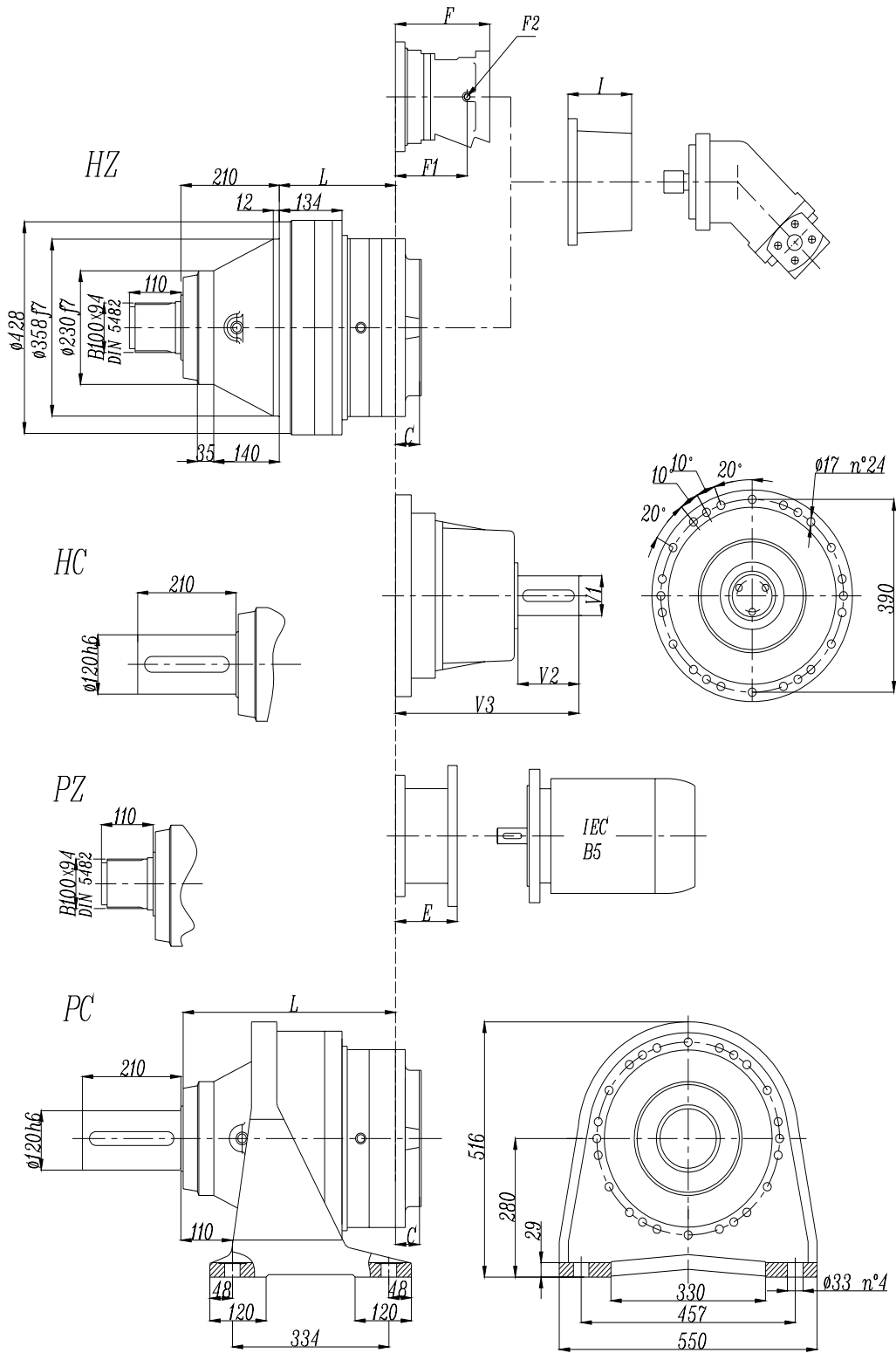

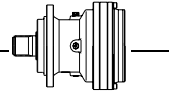

EP311 L

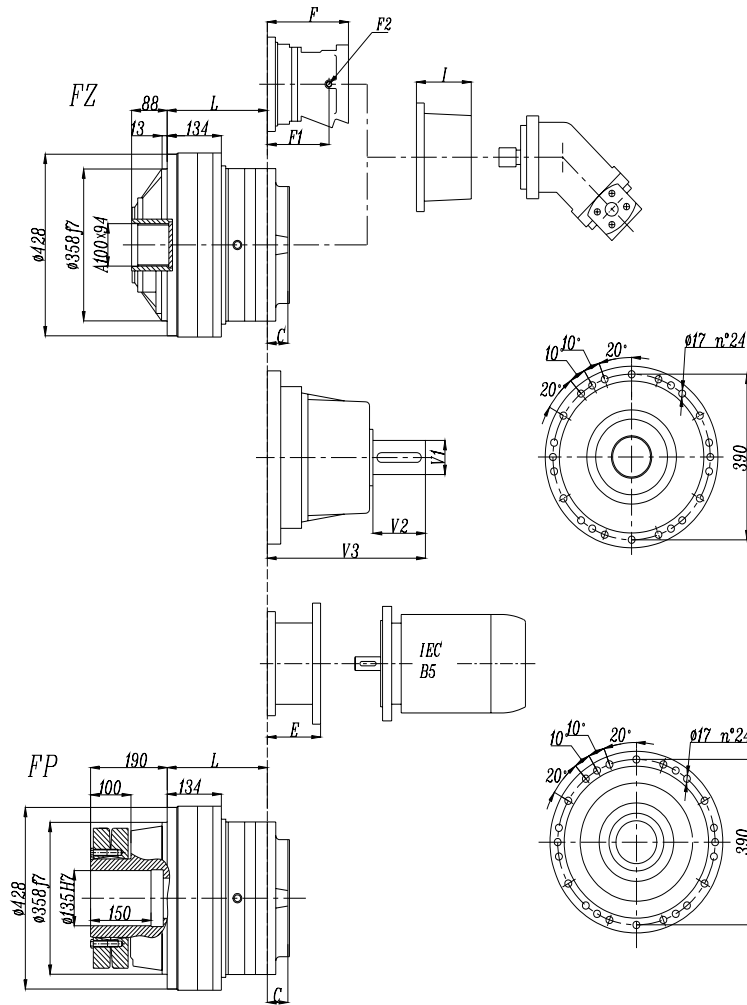

FP version

Max. transmissible

54000 N.m

	L				Ref. weight (without input) (Kg)				C	I	Brake				
	HZ HC	PC PZ	FZ	FP	HZ HC	PC PZ	FZ	FP			F	F1	F2	Type	Ref. Weight
311 L1	115	325	115	115	180	250	160	170	81	According to hydraulic motor					
311 L2	248	458	248	248	225	295	205	215	51		201	153	1/4 G	6	38 Kg
311 L3	341	551	341	341	237	307	217	227	37		145	95	1/4 G	5	22 Kg
311 L4	406	616	406	406	244	314	224	234	37		105	65	1/4 G	4	15 Kg

	E (IEC motor input)												
	IEC 71	IEC 80	IEC 90	IEC 100	IEC 112	IEC 132	IEC 160	IEC 180	IEC 200	IEC 225	IEC 250		
311 L1													
311 L2								195	186	216	215		
311 L3						114	144	144	174				
311 L4	65	84	84	94	94	114	144						

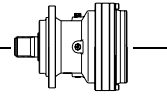

EP311 R

